

Technisches Datenblatt / Technical Datasheet

Art.-No. 64326

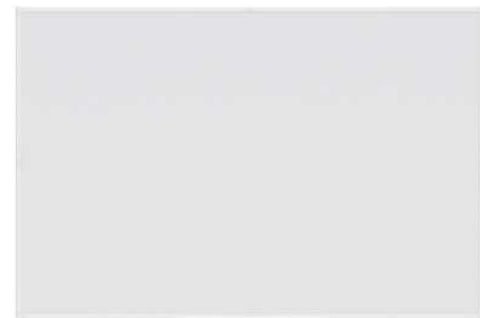

Vorderseite

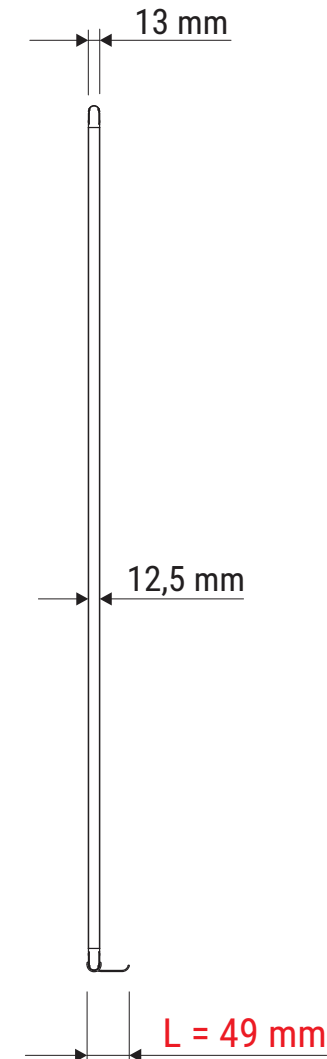
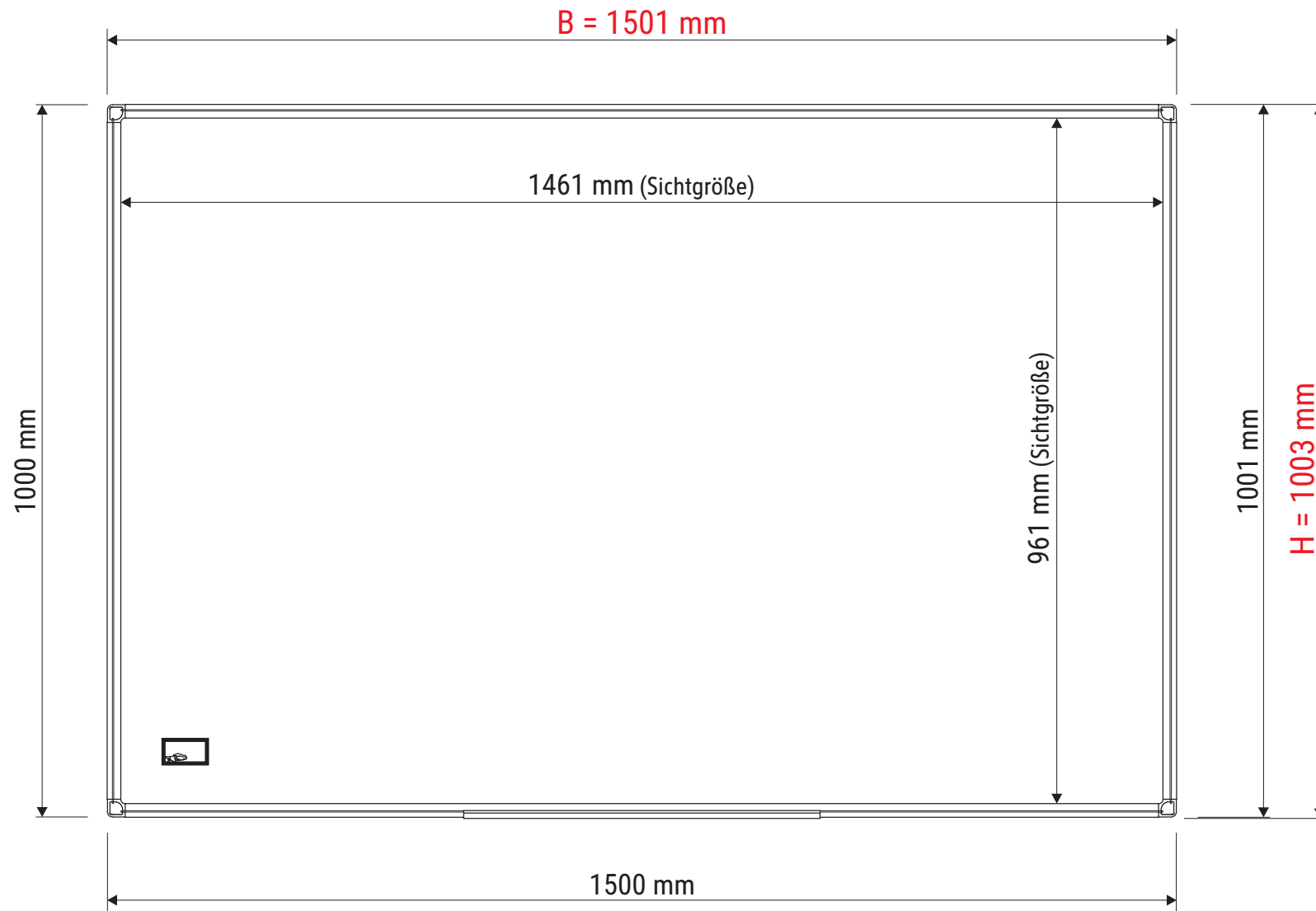

Zubehör inkl.:

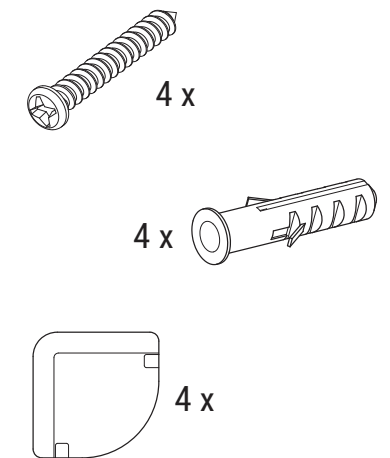

Montagematerial:
(als Ersatzteil lieferbar:
Abpackbeutel Art.-Nr.: 6430809.020)



1 x

(als Ersatzteil lieferbar:
Art.-Nr.: 6432609.050)

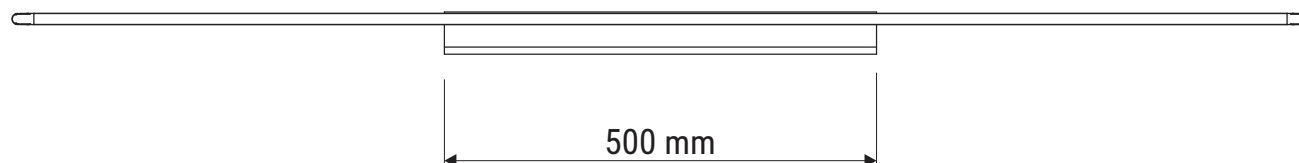

Abmaße Produkt: **L x B x H** (inkl. Schrauben, Dübel, Ablageschale, Abdeckung Ecken und ohne Schutzfolie)
49 x 1501 x 1003 mm
Gewicht: 4,850 kg

Verp. Abmaße : L x B x H (1 Stck. in Verp.)
1570 x 1070 x 35 mm
Gewicht kompl.: 7,393 kg

Technisches Datenblatt / Technical Datasheet

Art.-No. 64326

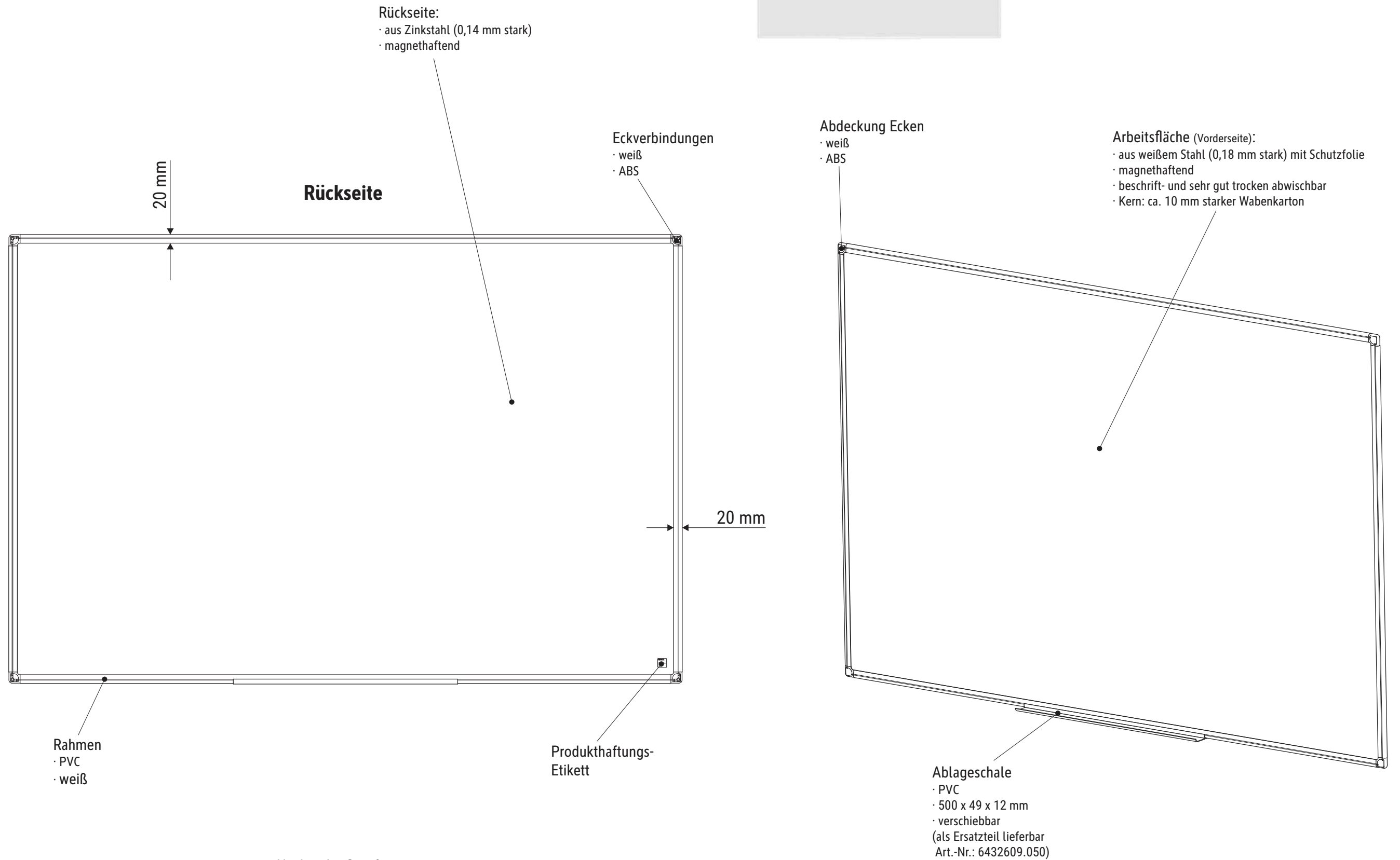

· Hoch- oder Querformat