

# Technisches Datenblatt / Technical Datasheet

## Art.-No. 64603

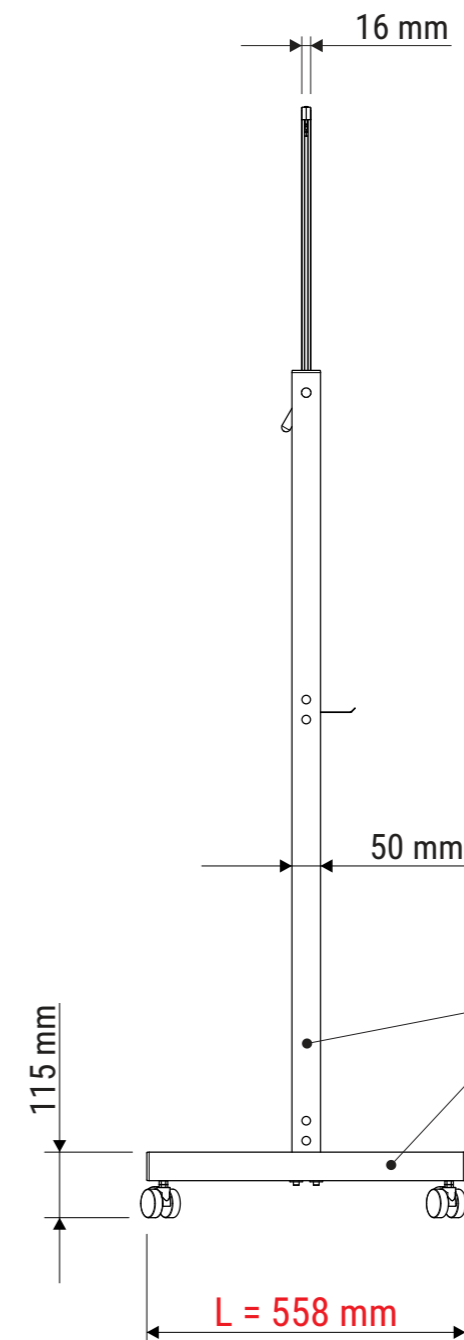
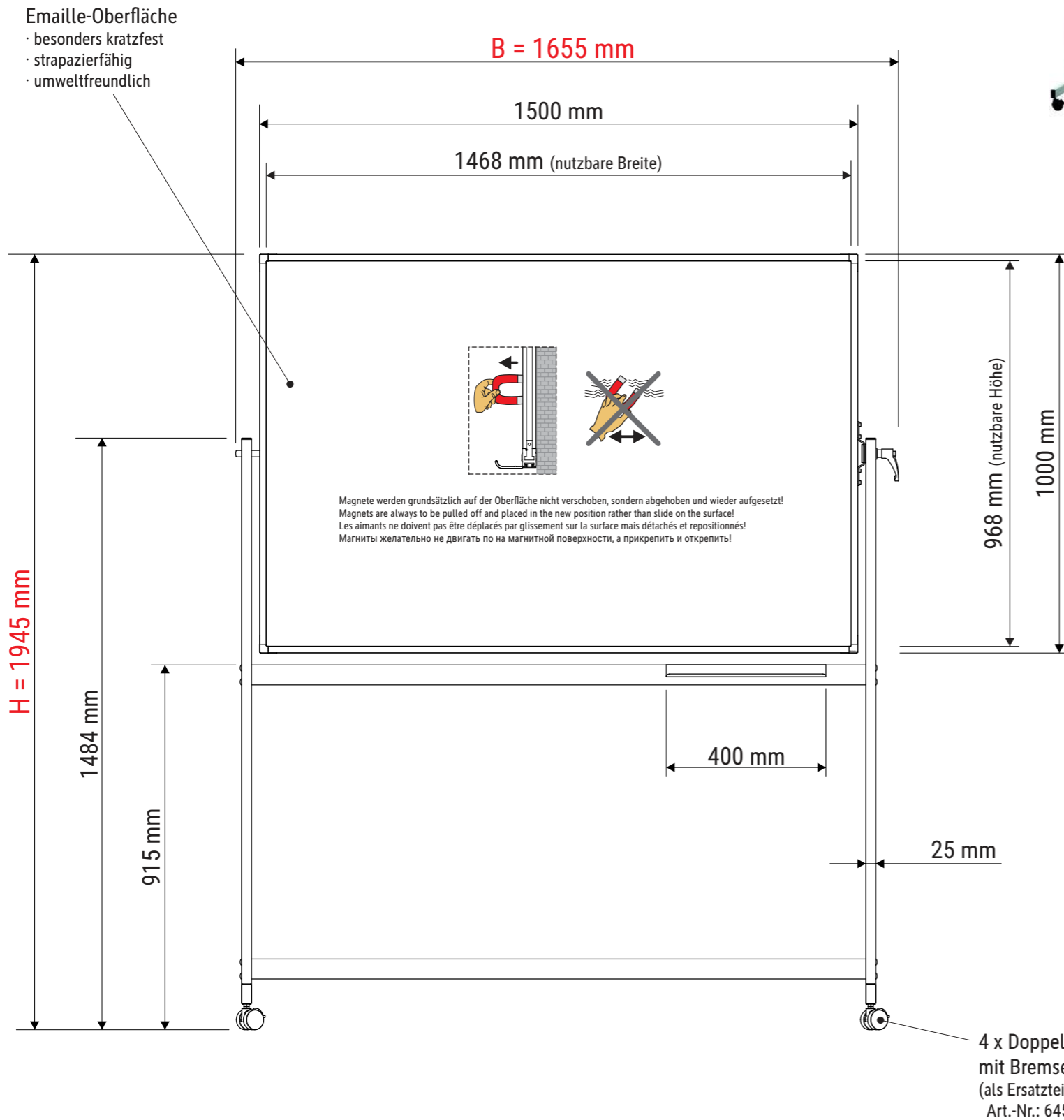

Abmaße Produkt: **L x B x H**  
 558 x 1655 x 1945 mm  
 Gewicht: 21,850 kg

Verp. Abmaße : L x B x H  
 1660 x 1090 x 75 mm  
 Gewicht kompl.: 28,597 kg

# Technisches Datenblatt / Technical Datasheet

## Art.-No. 64603



- um 360° drehbar
- stufenlose Schrägstellung
- Oberfläche leicht zu reinigen, säuren- und laugenresistent, korrosionsgeschützt

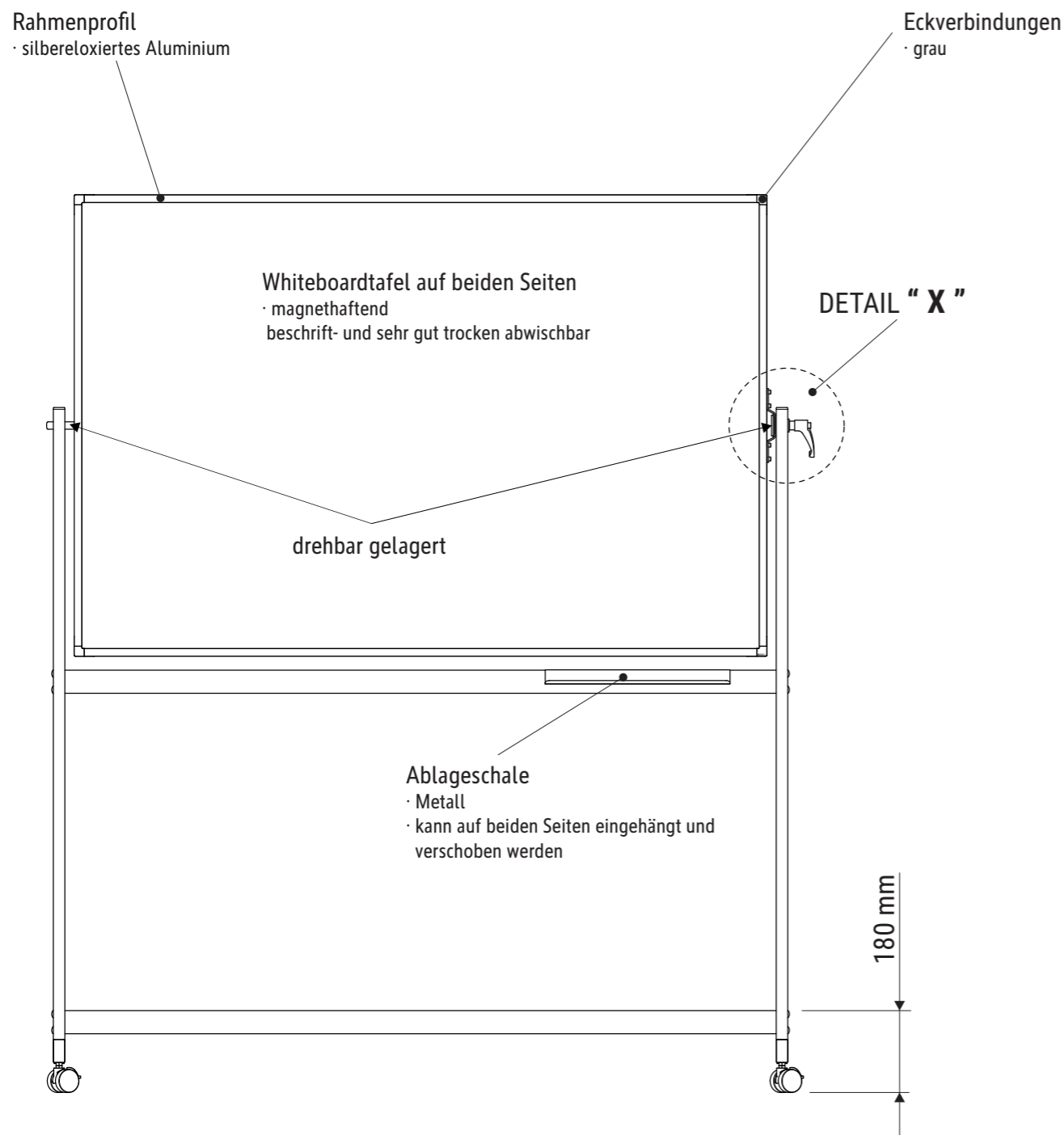

Detail „X“

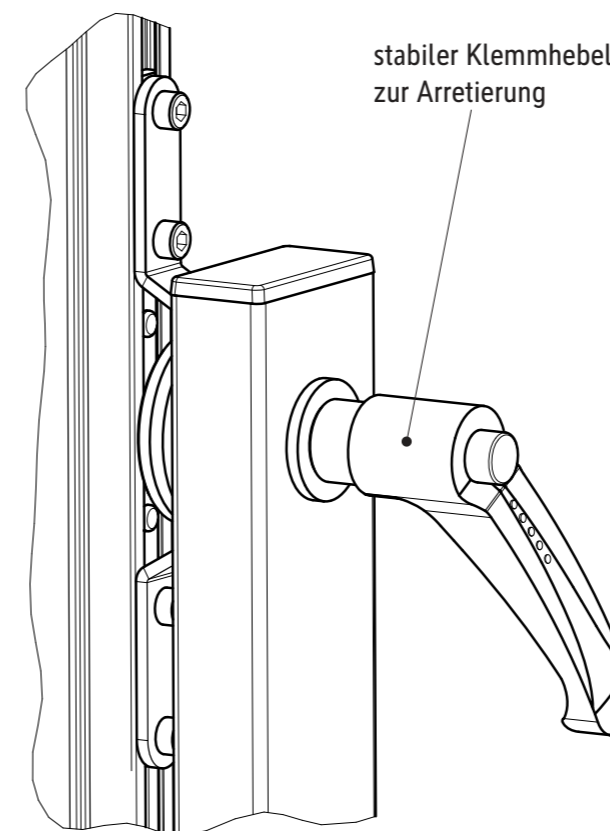

### Montagematerial:

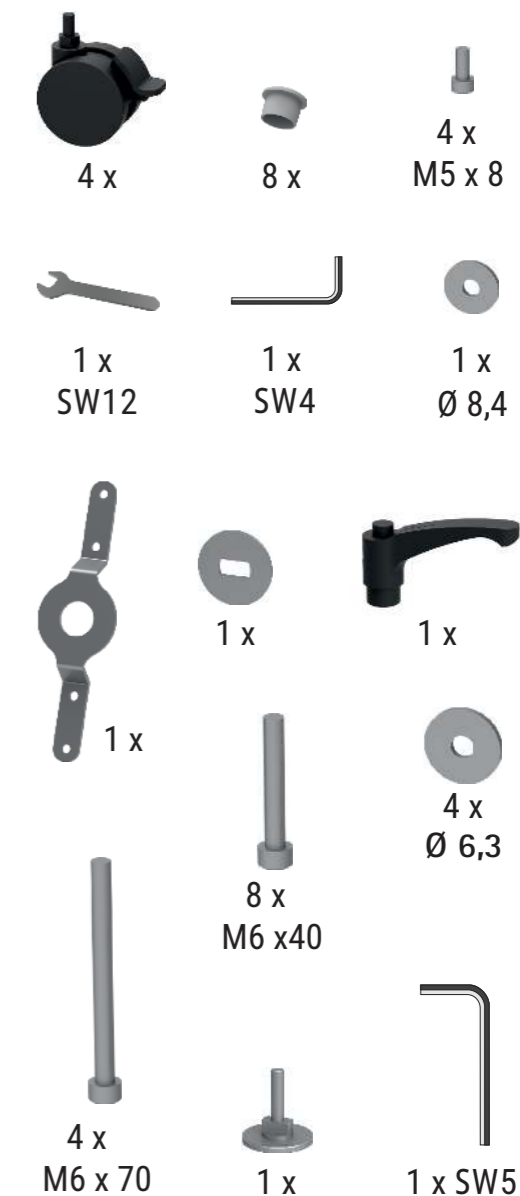

**komplett als Ersatzteil lieferbar:**  
**Art.-Nr.: 6459309.020**