

MAULjuvis 825 86

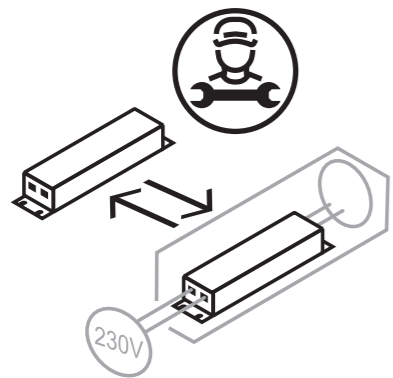

CEE 7/7

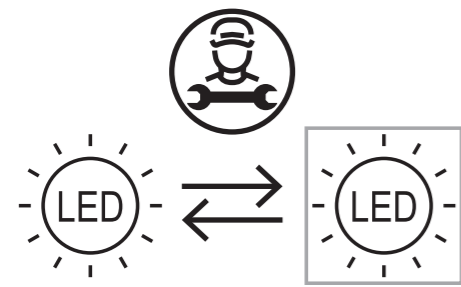
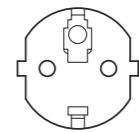
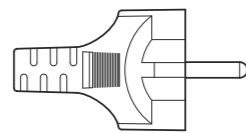

200-240V~
50/60 Hz
80W

ca.
2,50 m

www.maul.de

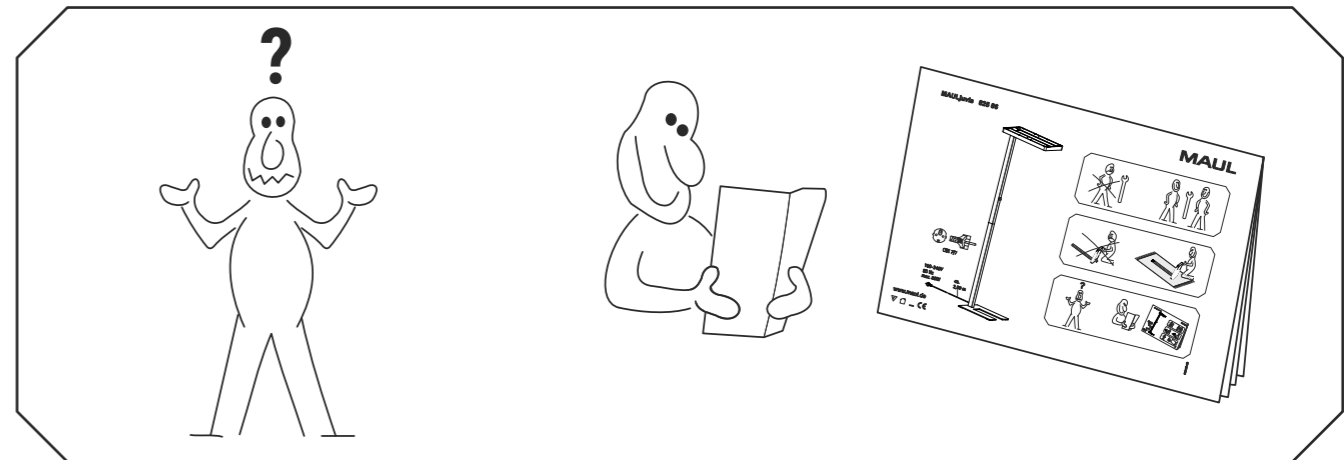
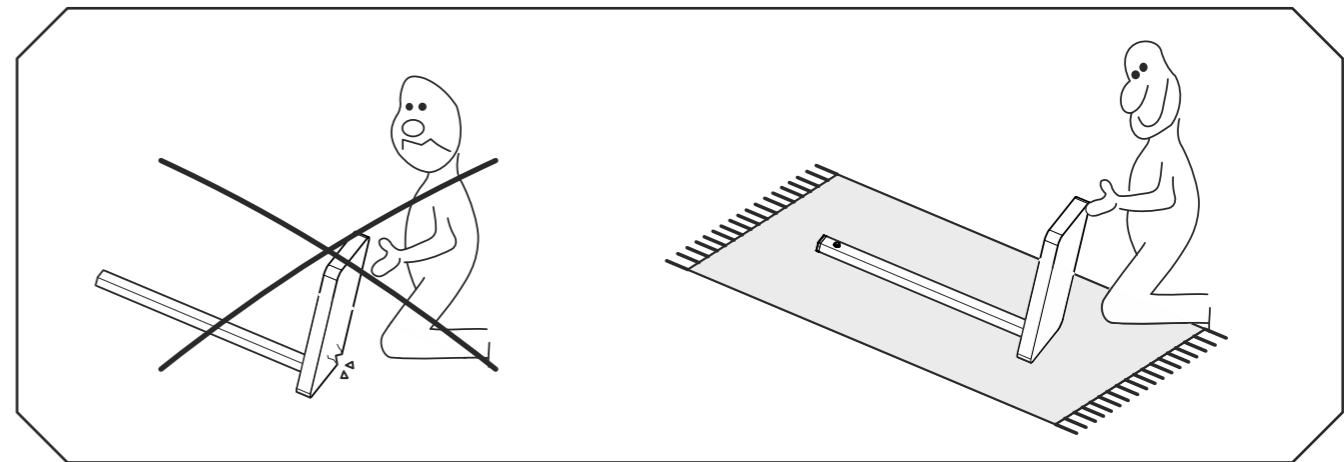
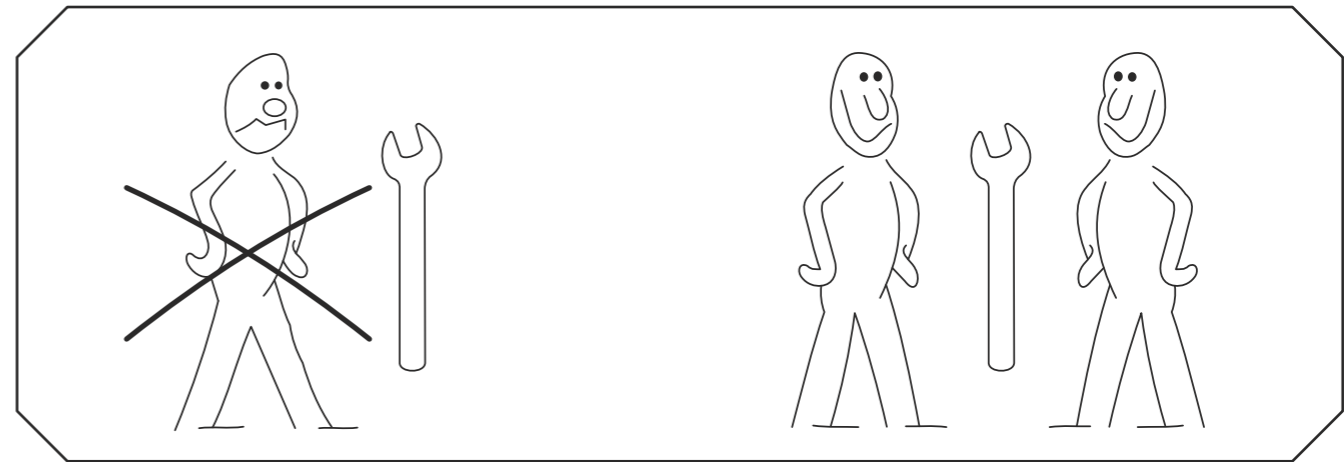
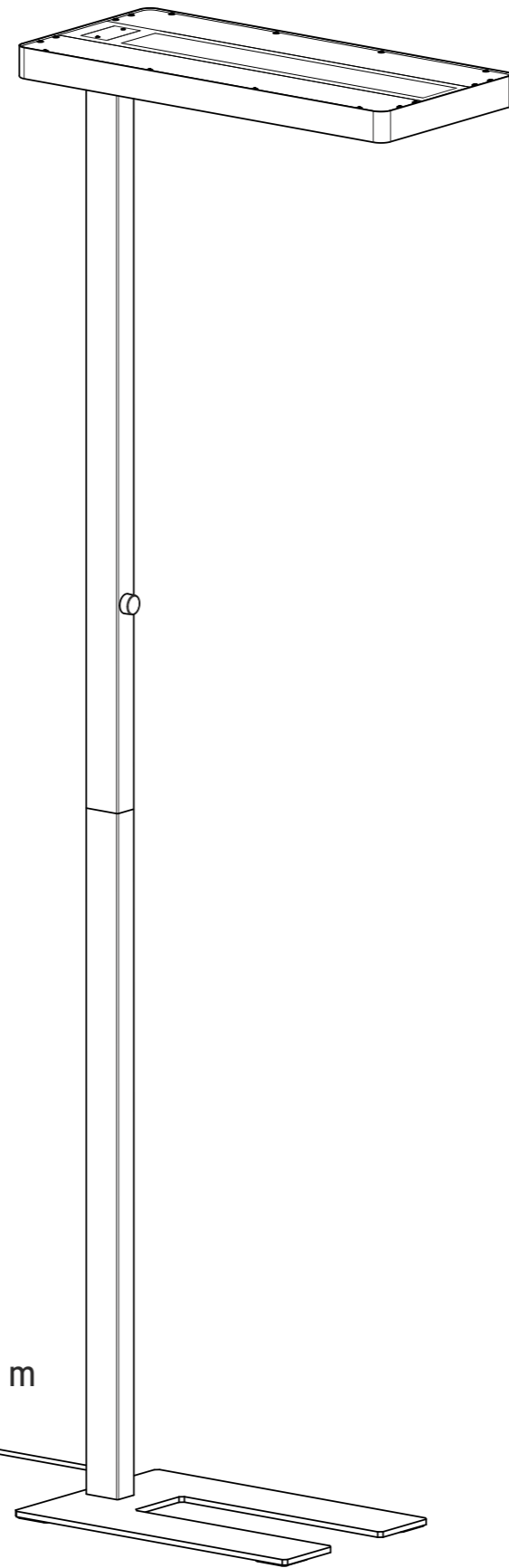

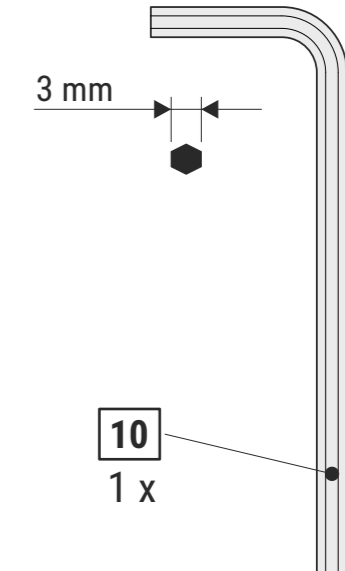
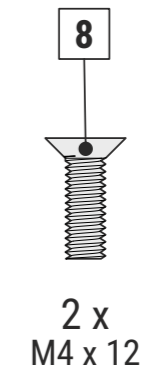
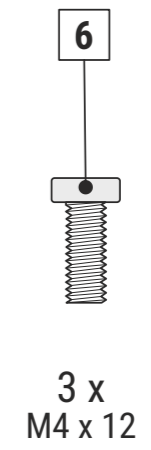
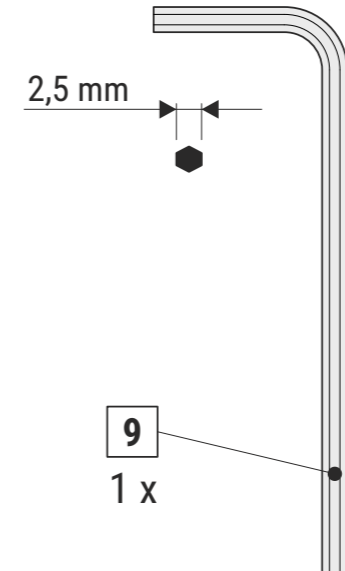
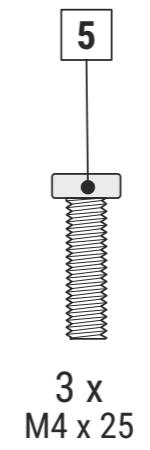
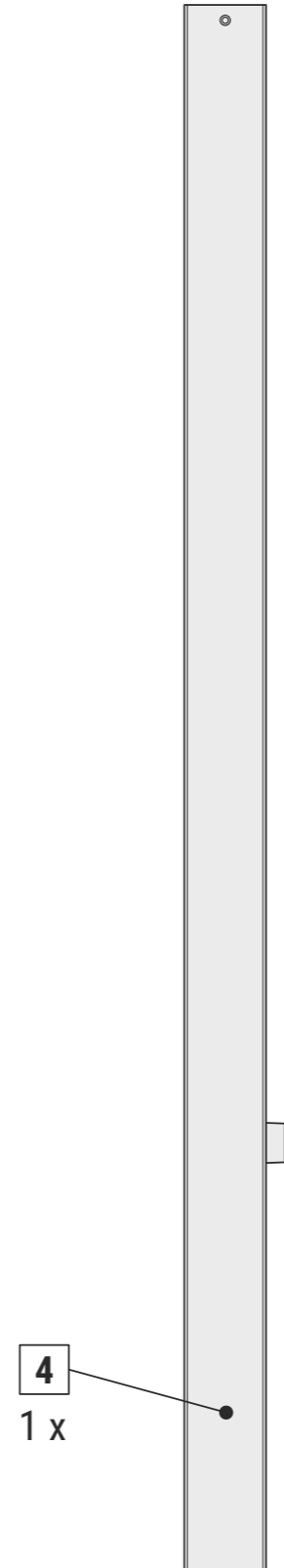
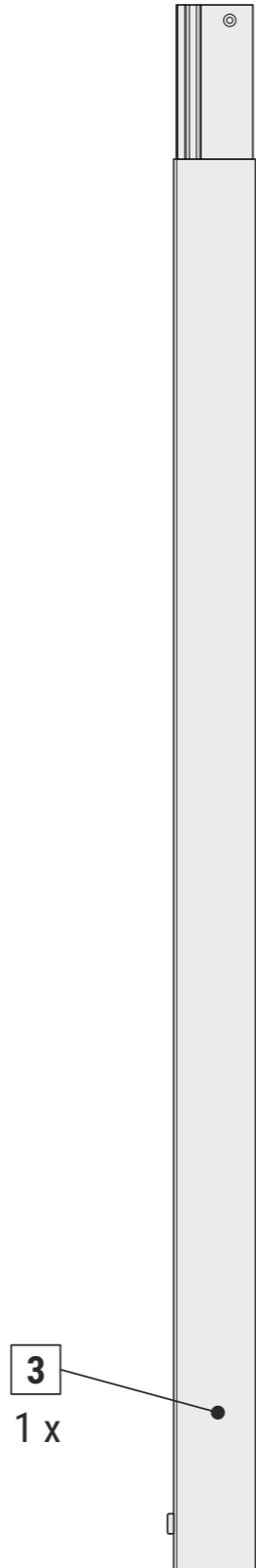
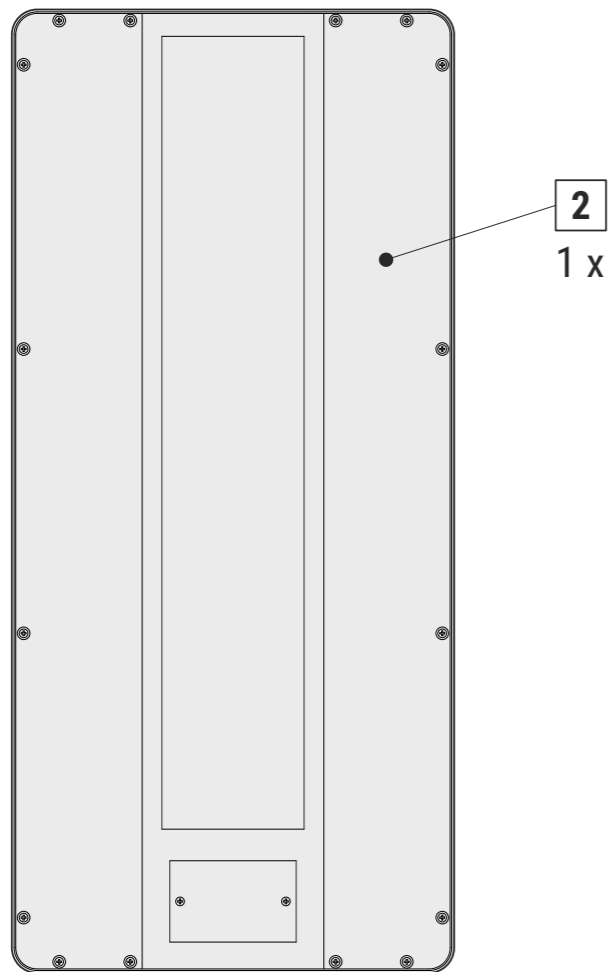
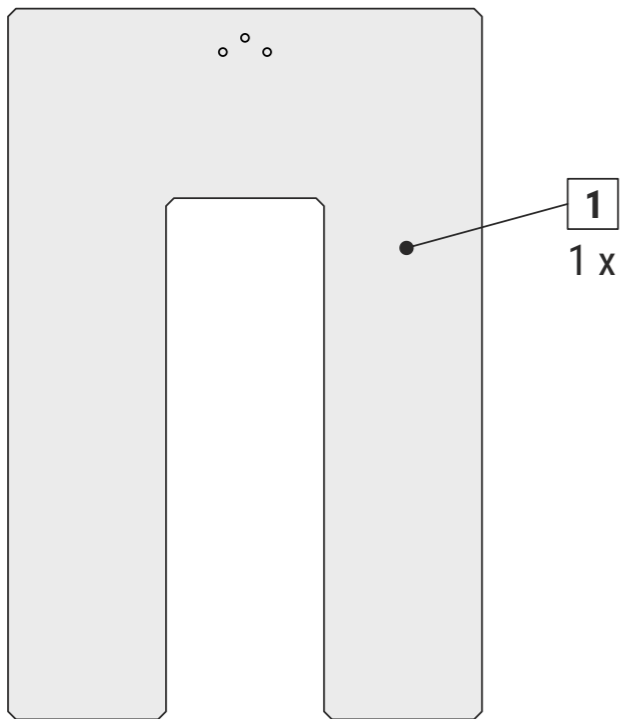

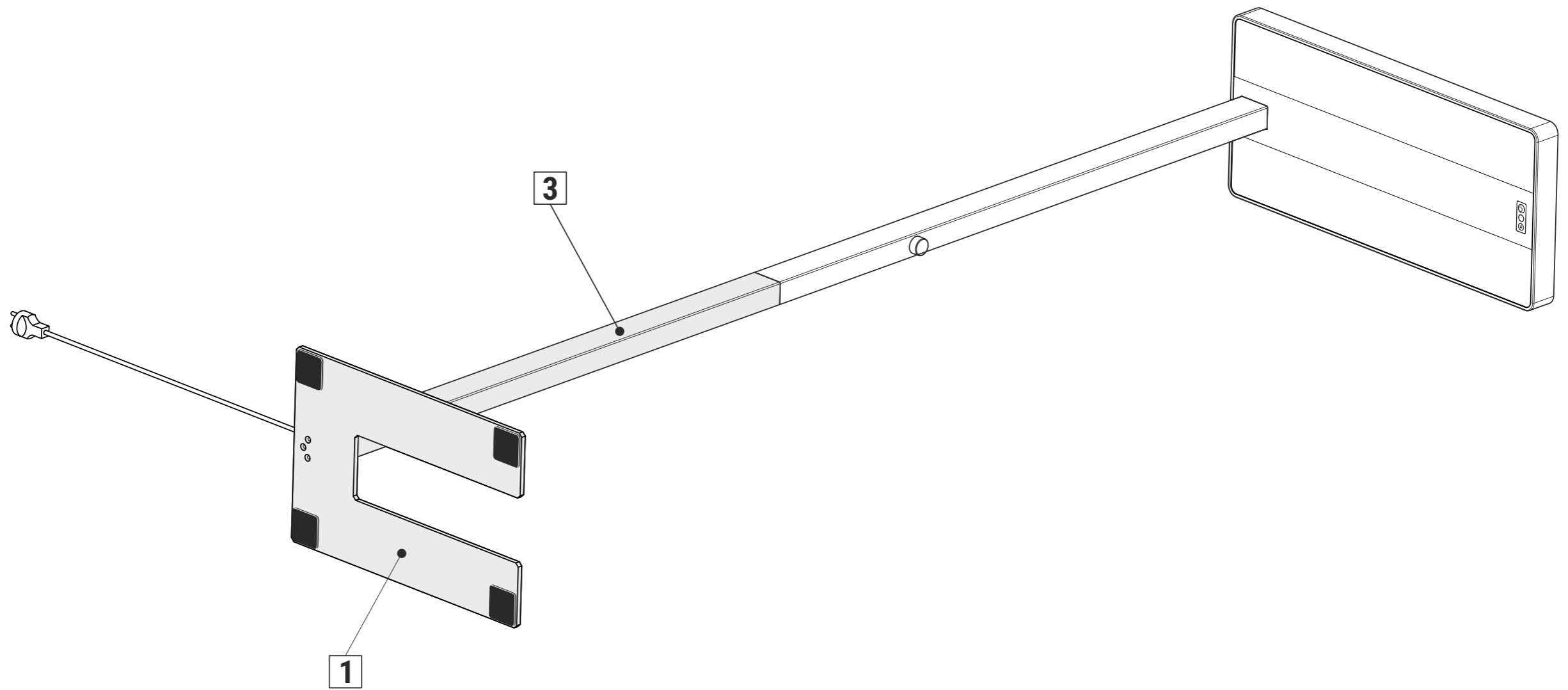

1

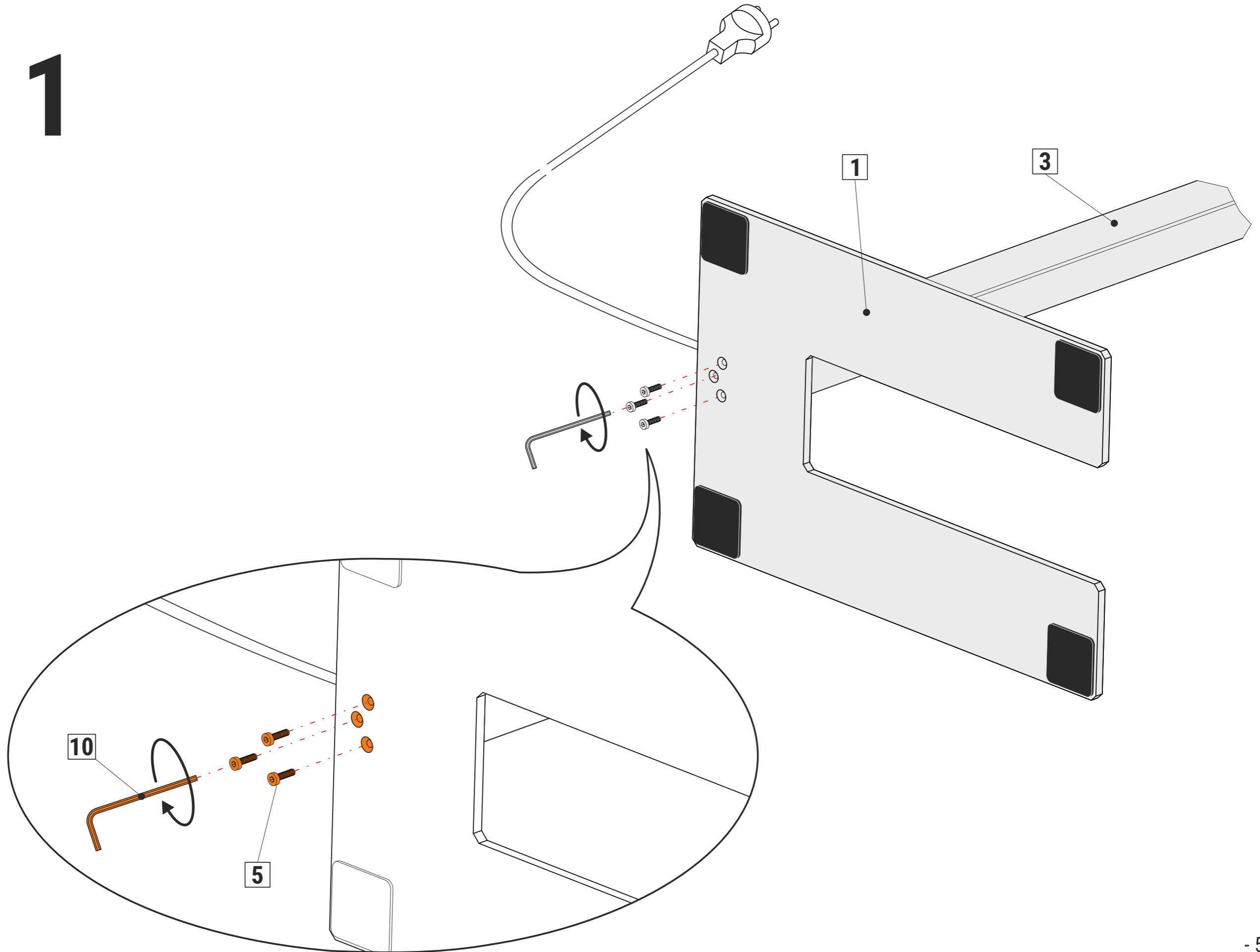

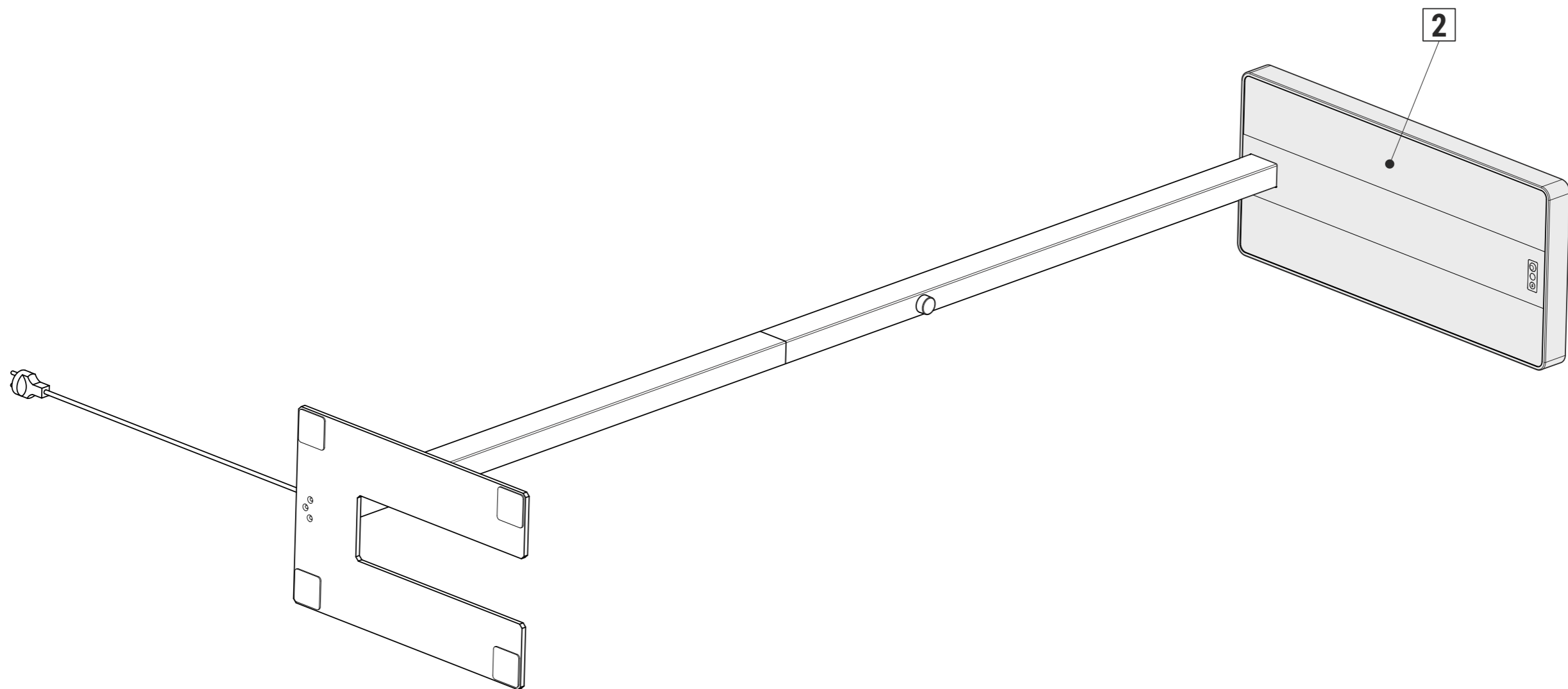

2

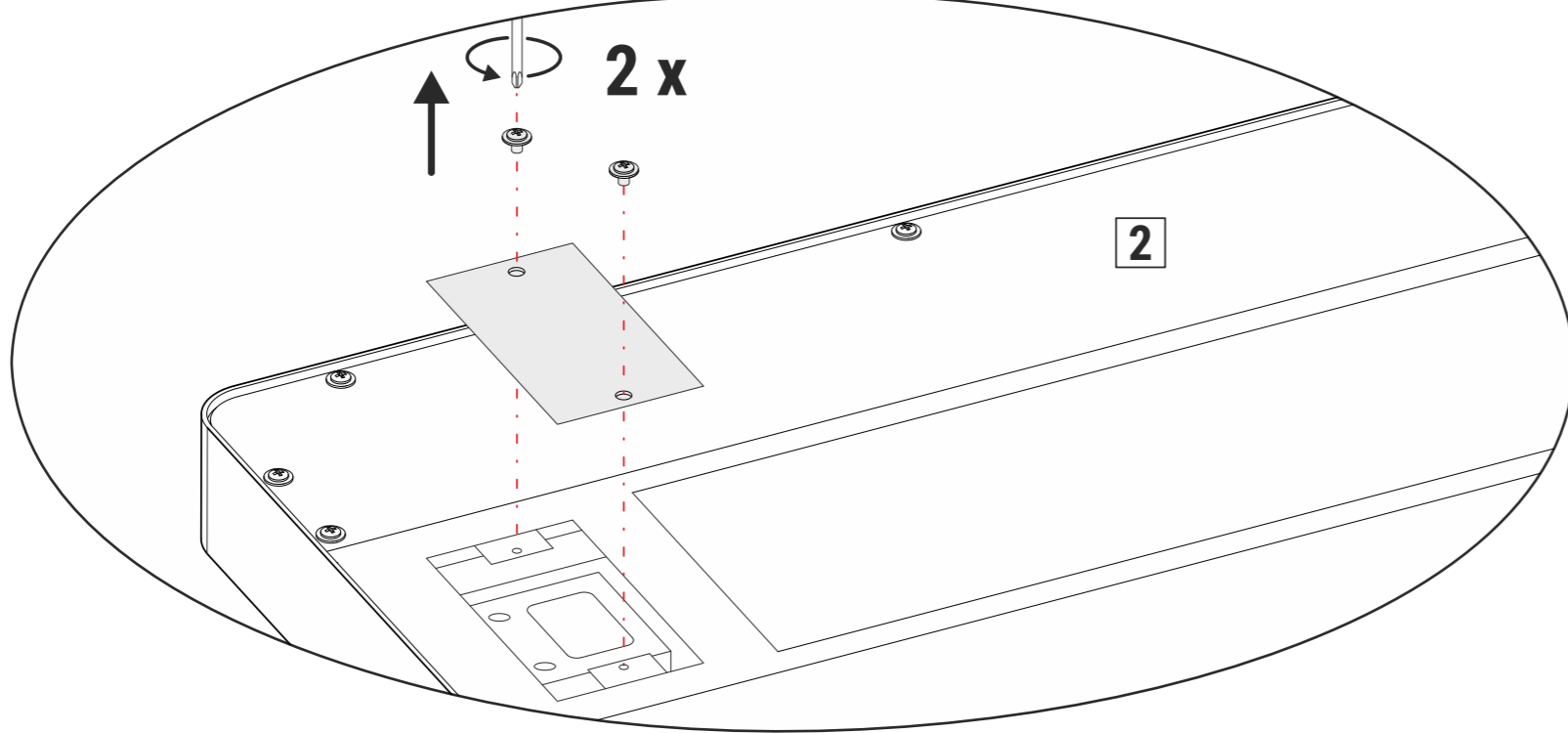
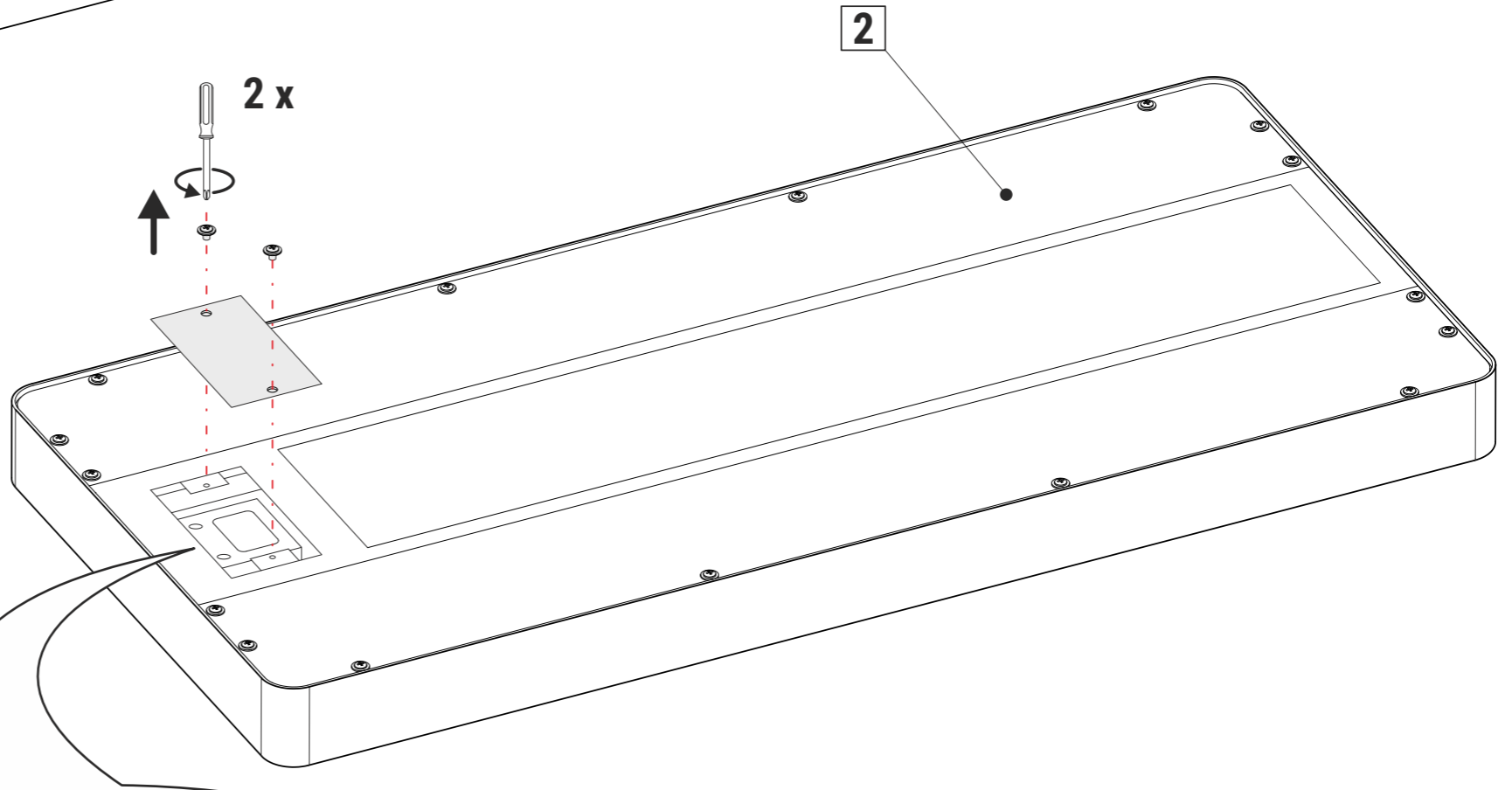
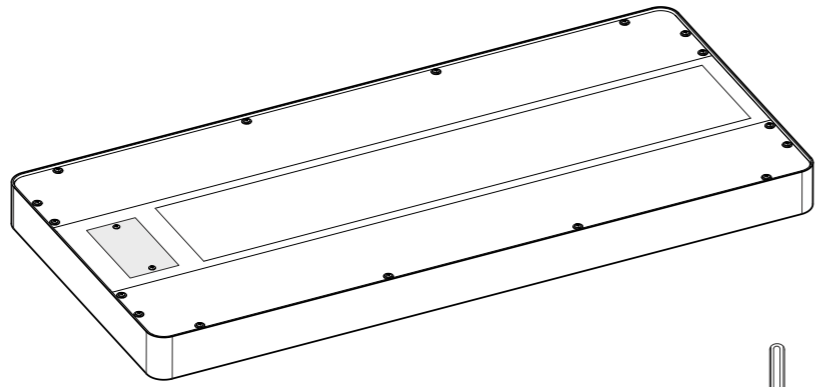

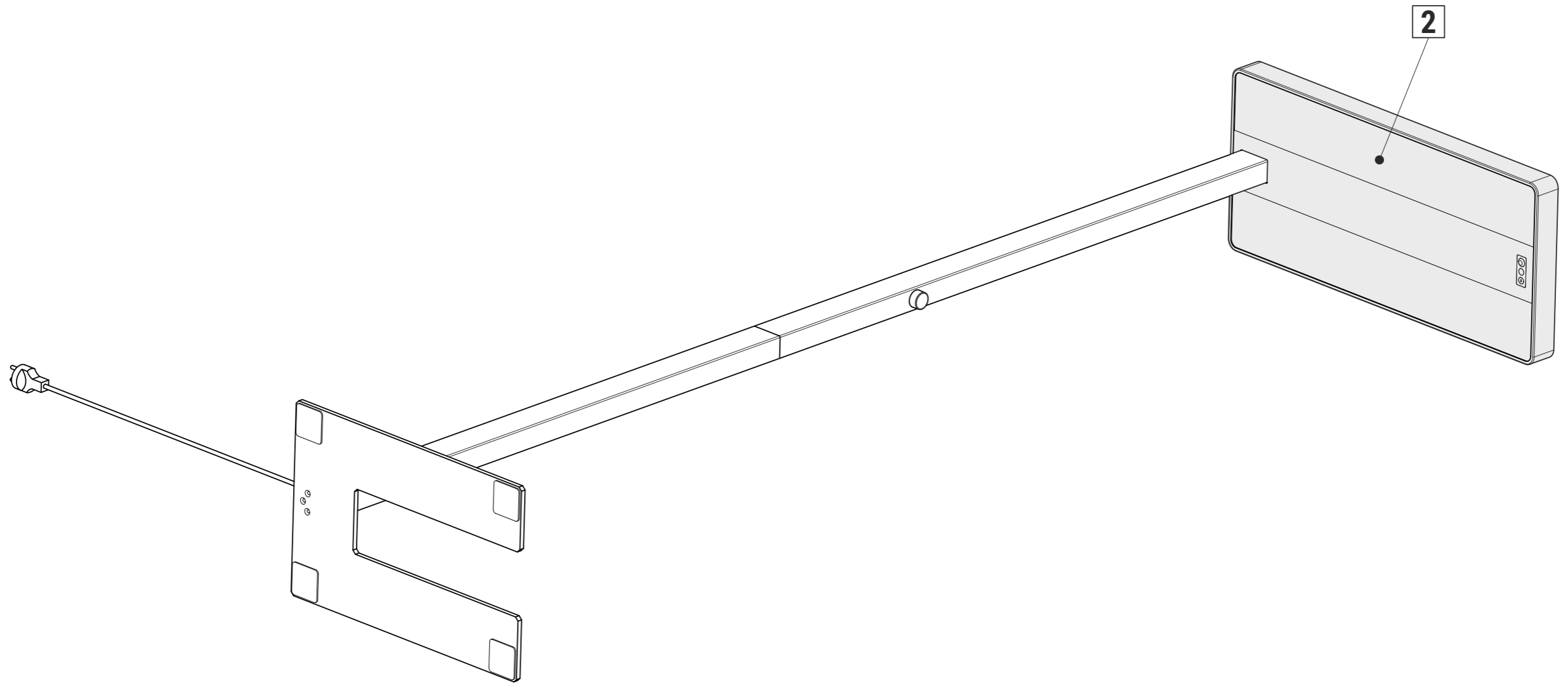

3

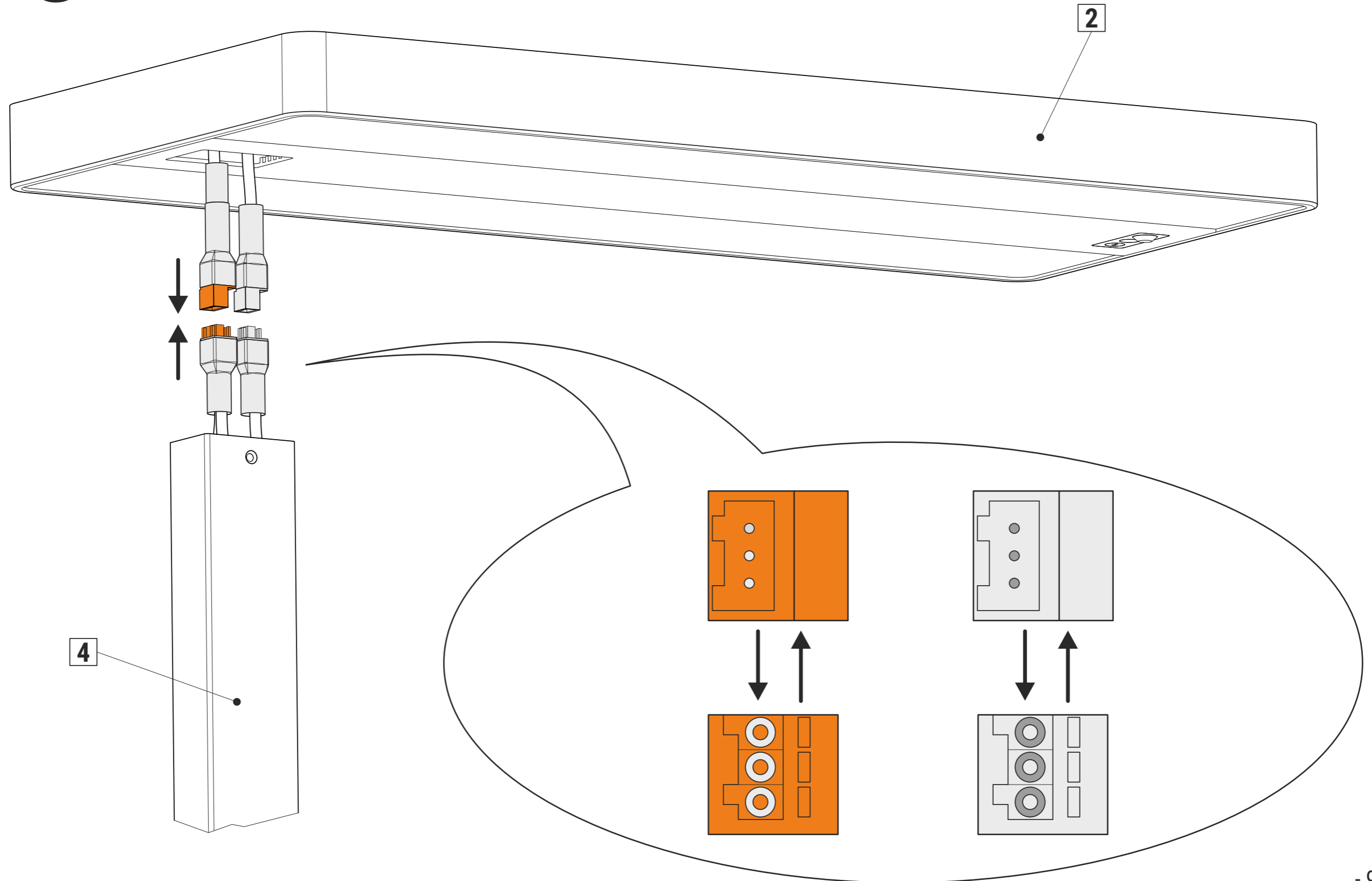

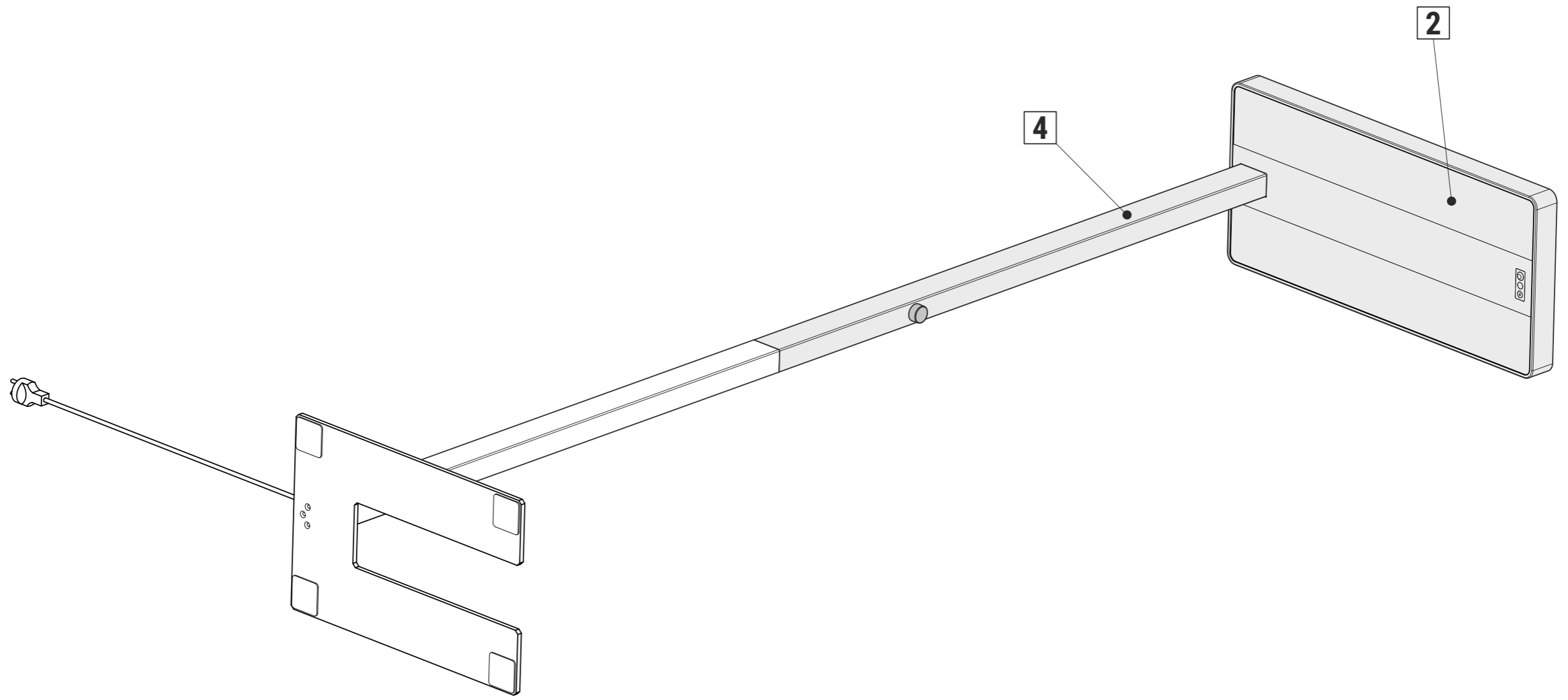

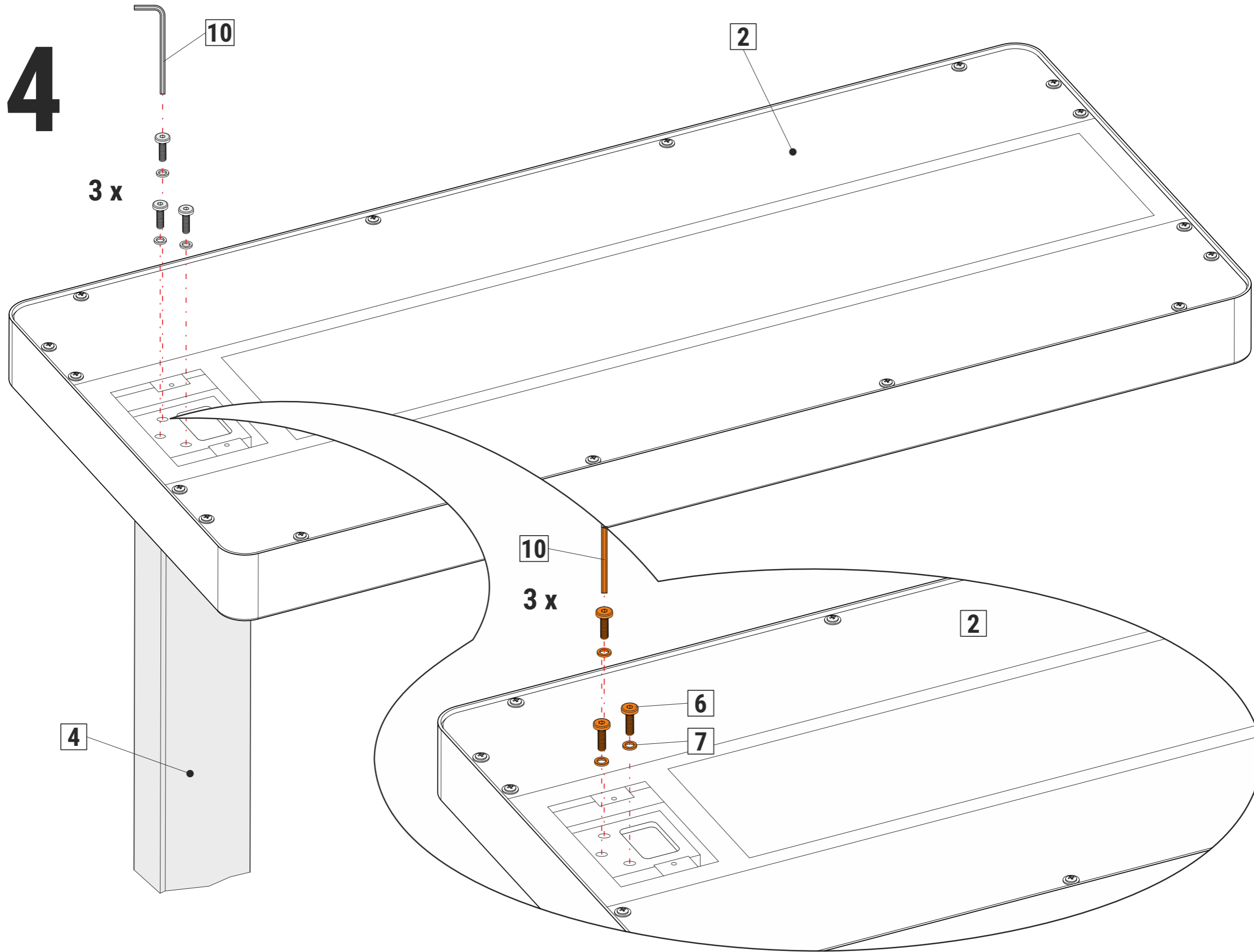

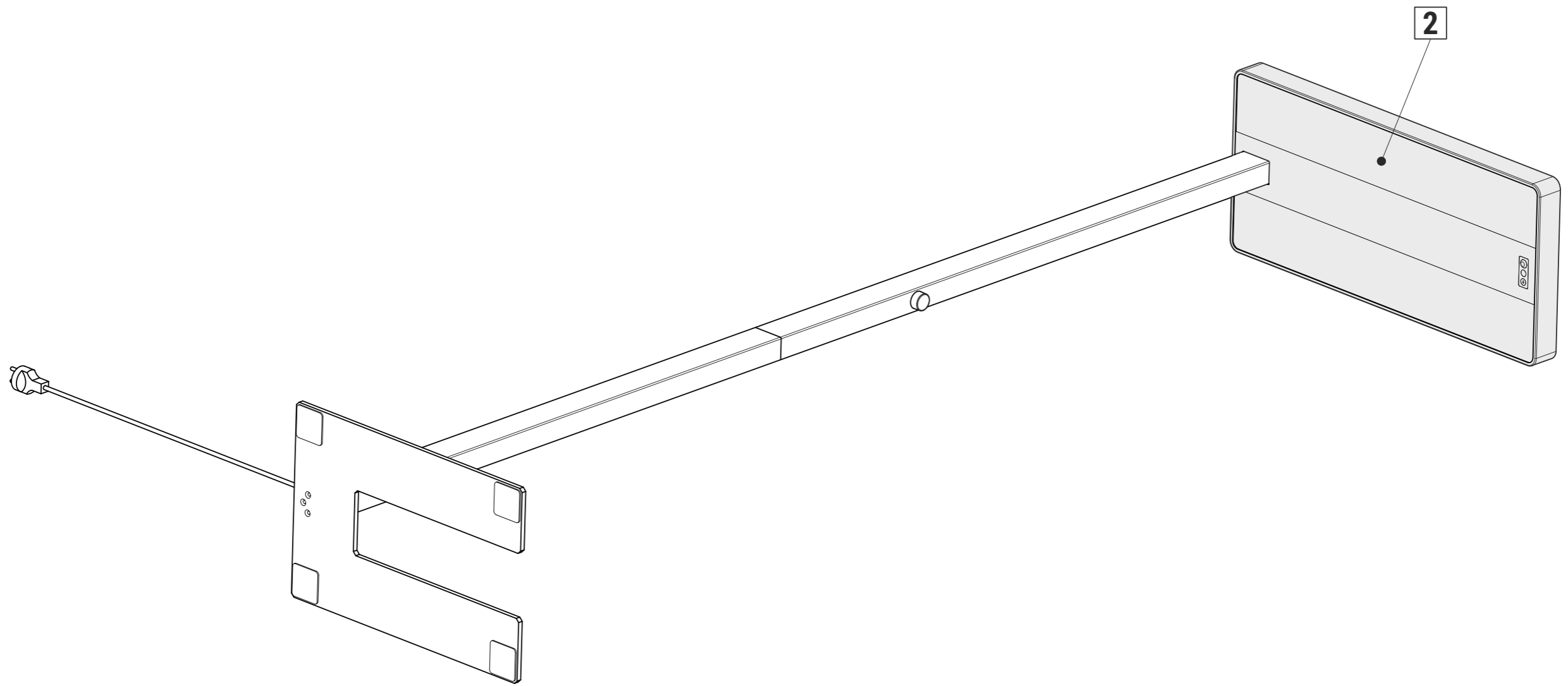

5

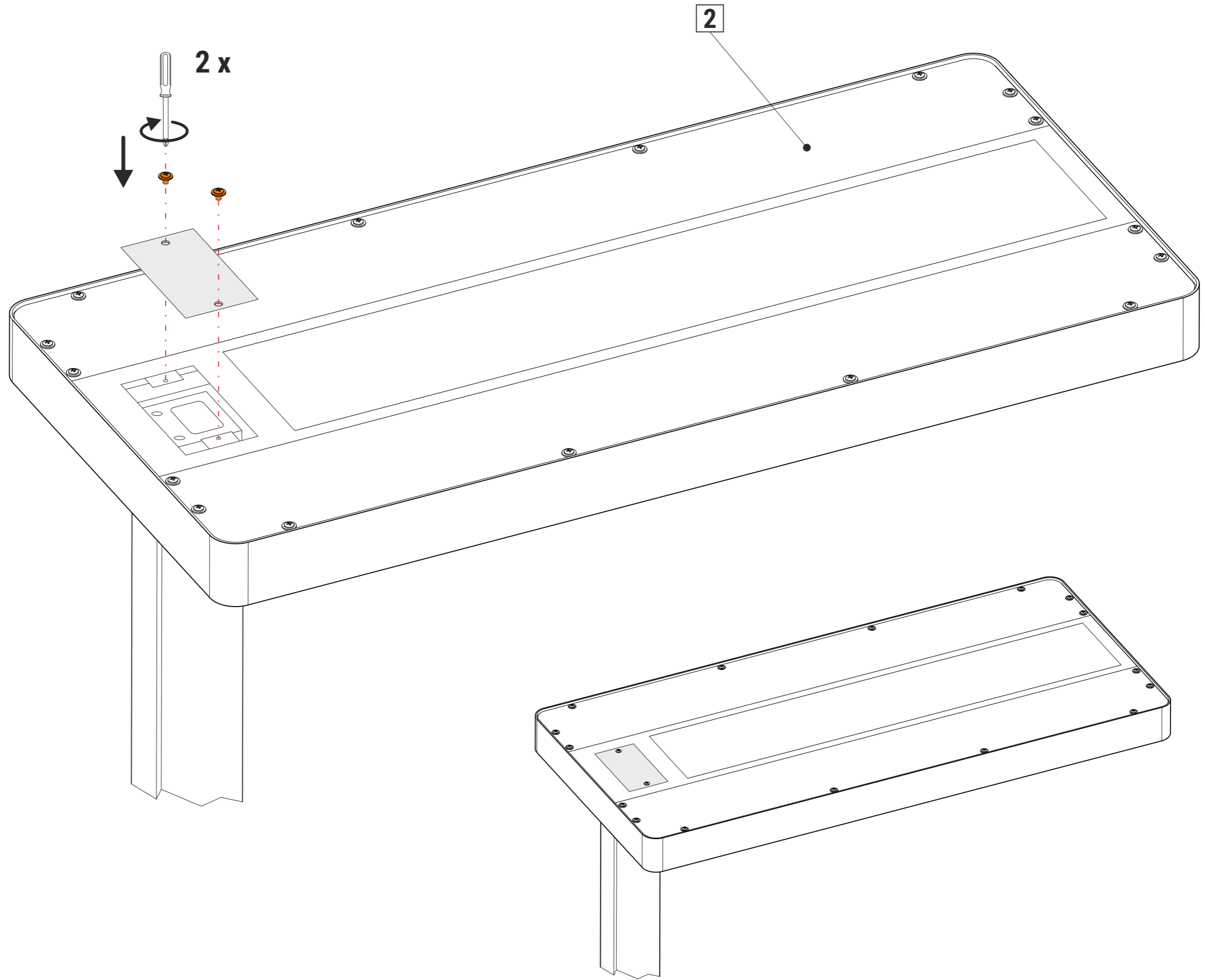

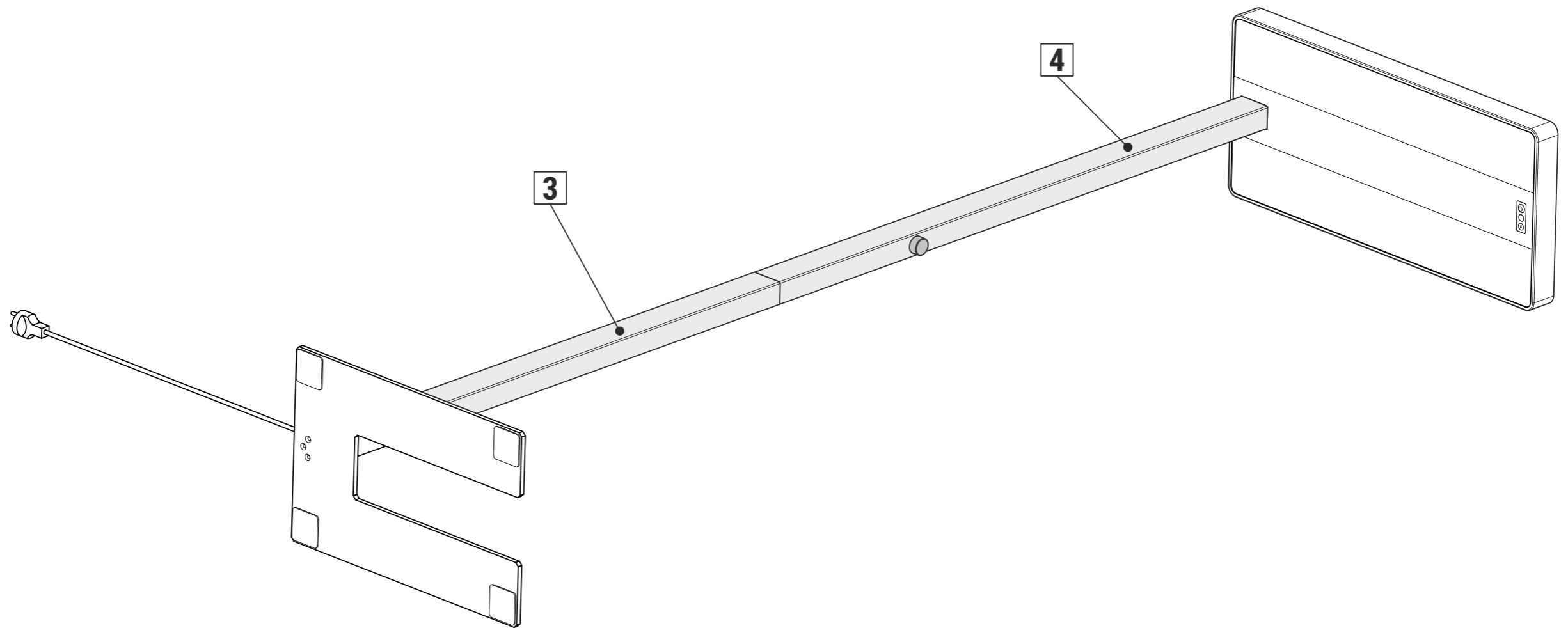

6

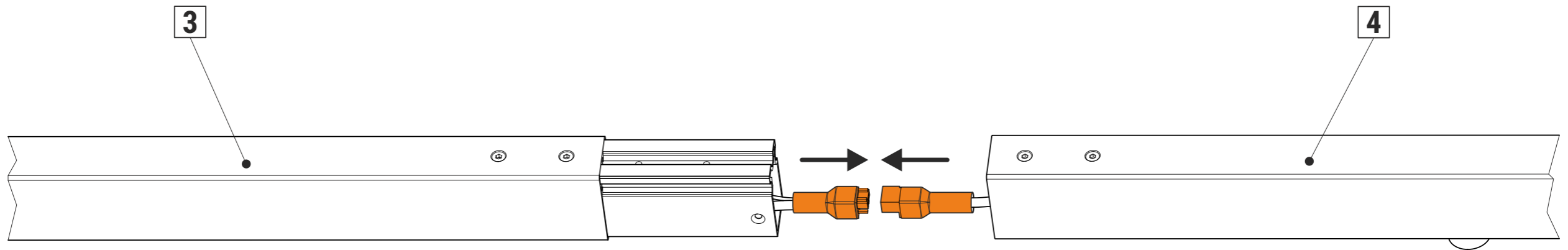

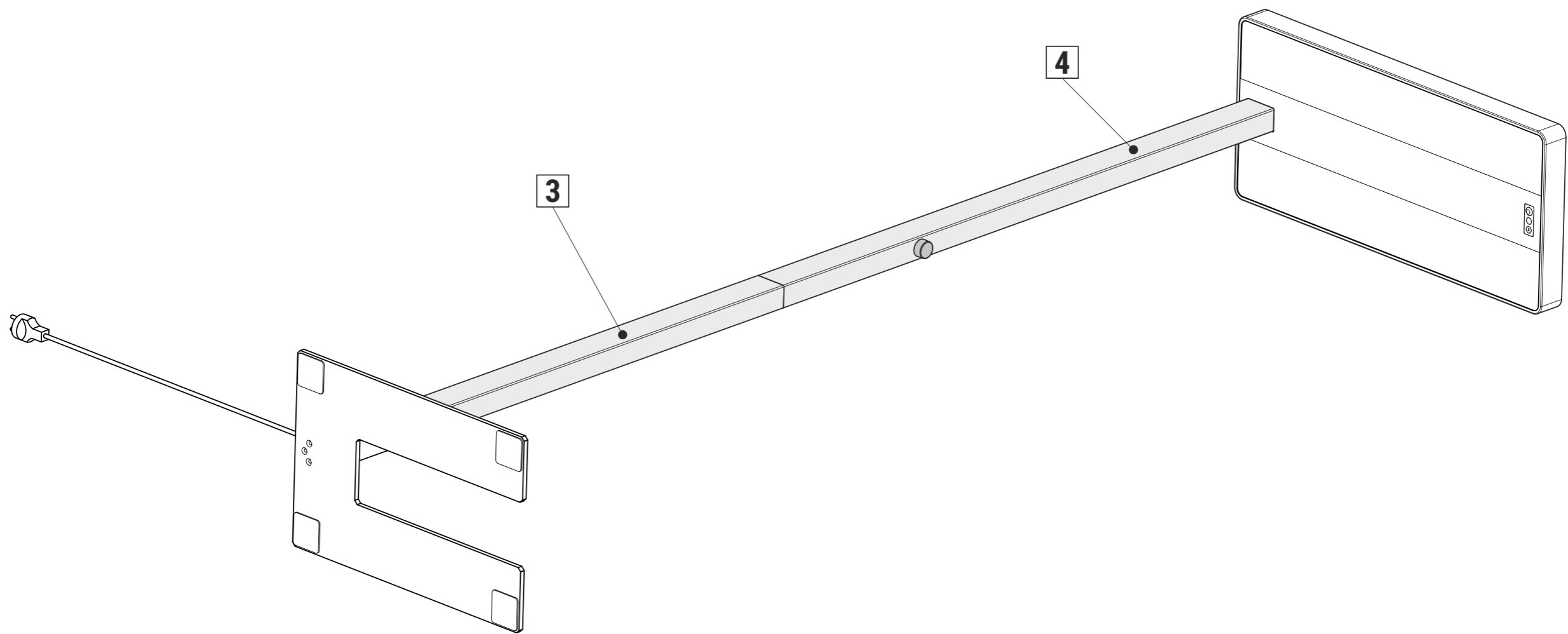

7

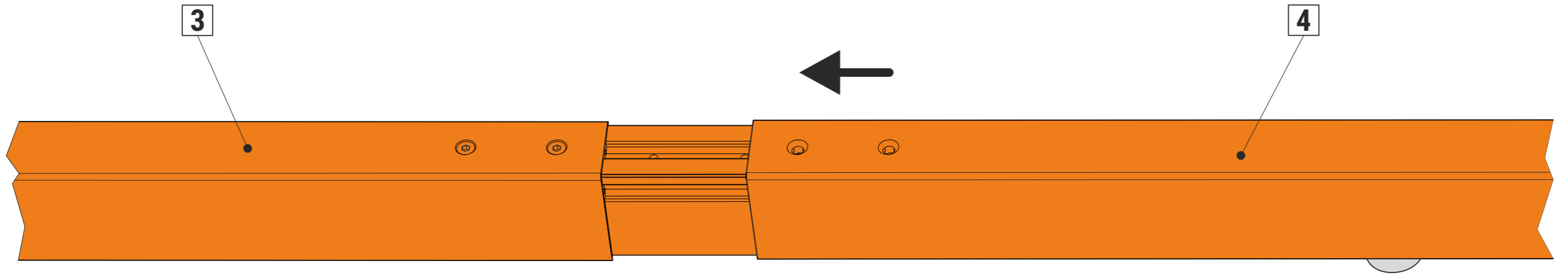

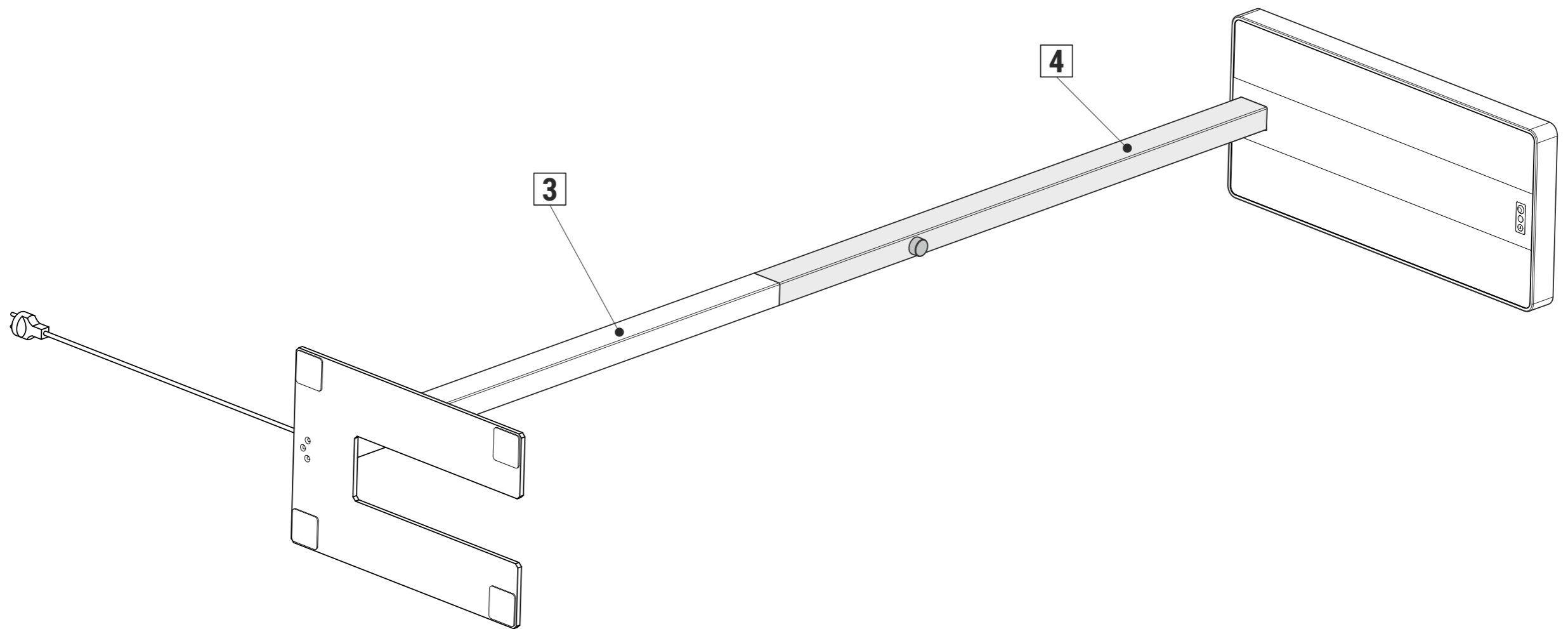

8

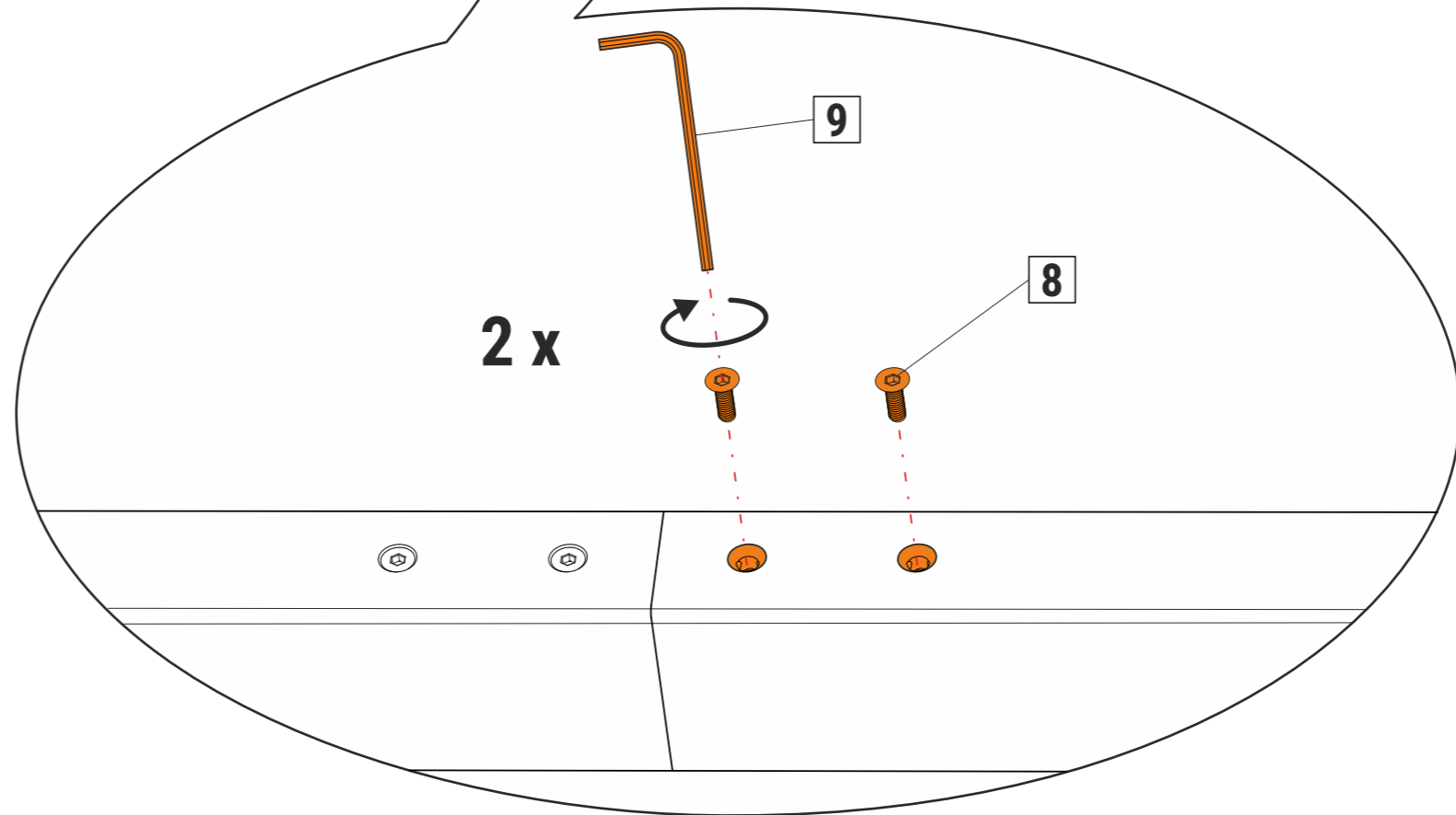
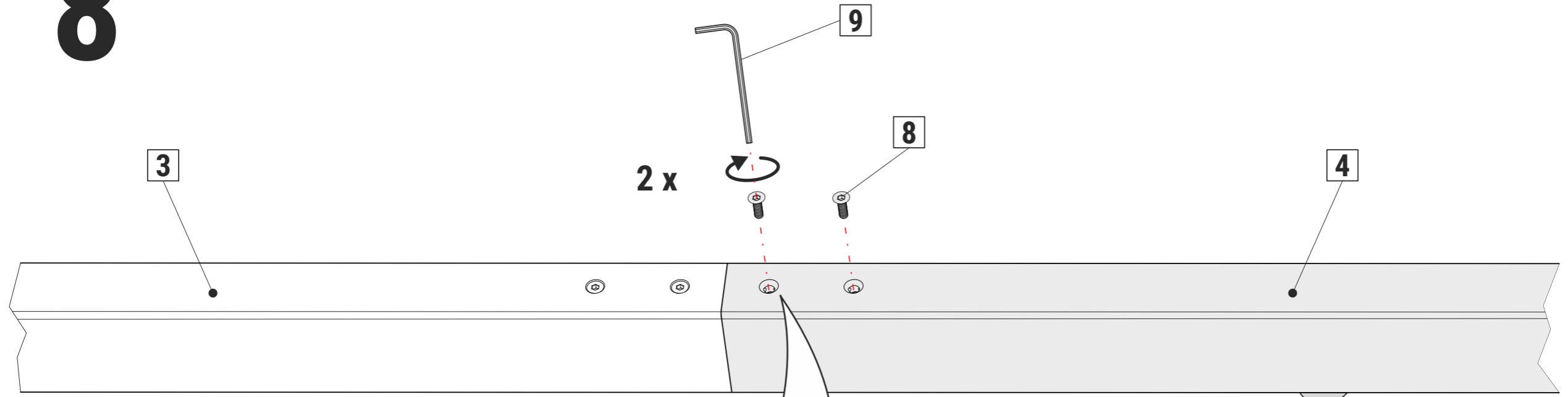

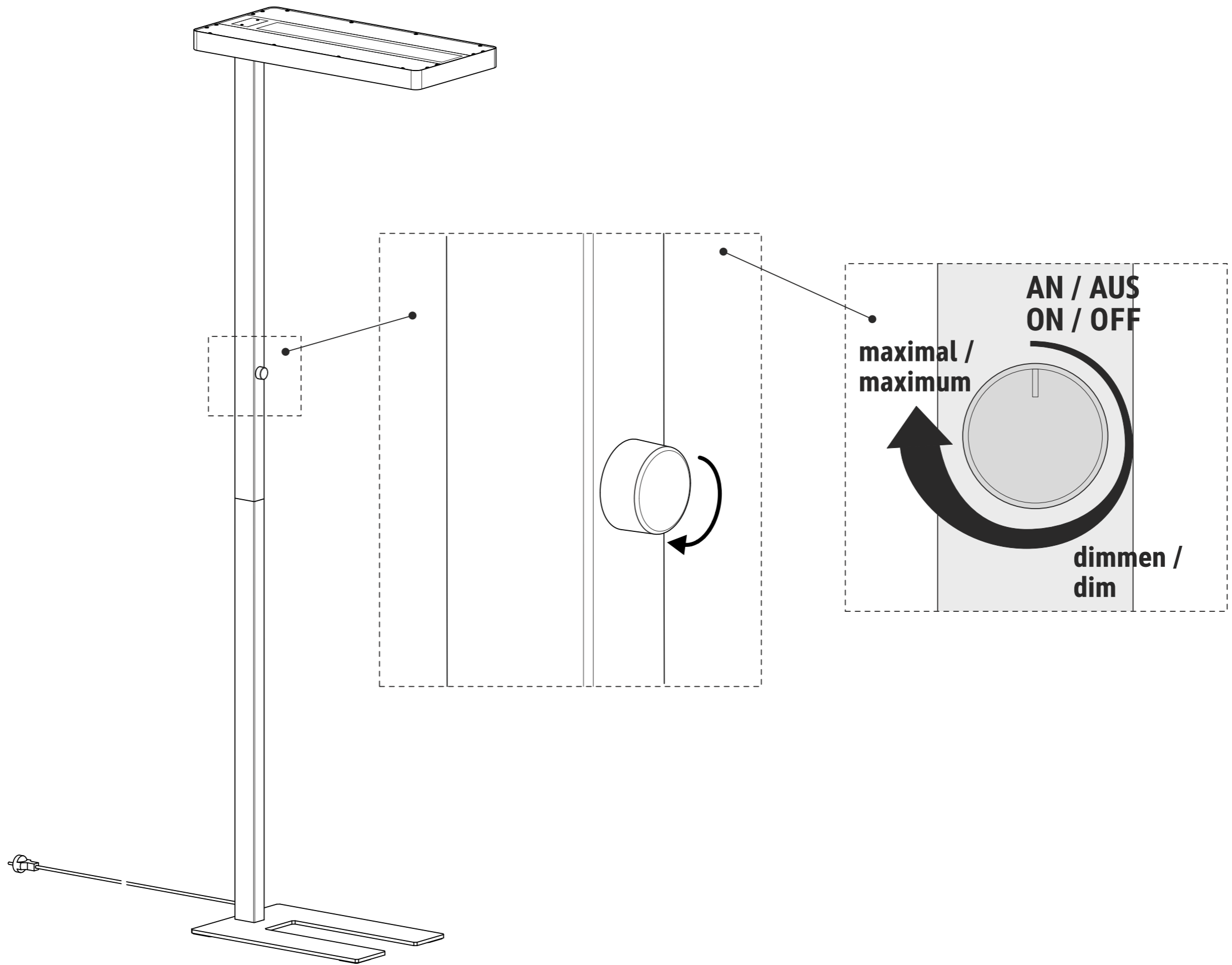

Bewegungssensor / Motion Sensor & Tageslicht-Sensor / Daylight Sensor

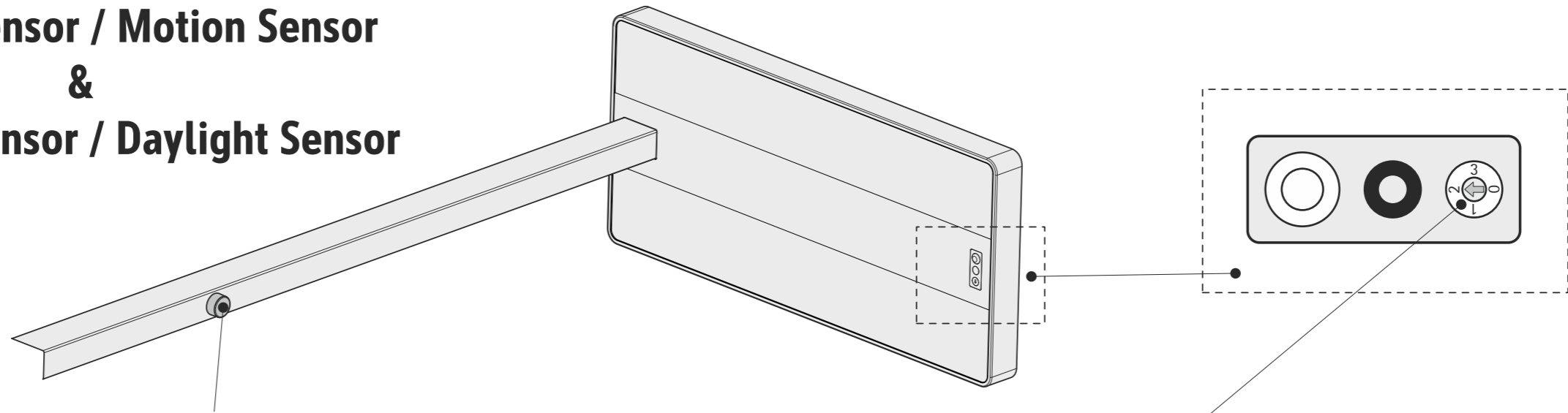

Hinweis zur Kalibrierung des Lichtsensors:

Nach Herstellung der Spannungsversorgung mit dem Netzstecker und der Wahl des Betriebsmodus ("Dip switch"-Position 2 oder 3) zur Aktivierung des Lichtsensors kann das Anschalten der Leuchte über den Dreh-Schalter erfolgen. Darauf folgend kalibriert sich der Lichtsensor in wenigen Minuten auf die räumlichen Bedingungen, bevor eine Anpassung der Leuchte an die Beleuchtungsstärkeverhältnisse erfolgt.

Note regarding the calibration of the light sensor:

After connecting the mains plug to a power outlet and selecting the operating mode ("dip-switch"-position 2 or 3) to activate the light sensor, the luminaire can be switched on using the rotary switch. The light sensor will then calibrate itself to room lighting within a few minutes before adapting the luminaire to the general illumination level.

Note concernant le calibrage du capteur de lumière:

Après avoir branché la prise au secteur et avoir sélectionné le mode de fonctionnement ("dip switch"-position 2 ou 3) pour activer le capteur de lumière, vous pouvez allumer le luminaire par le commutateur rotatif. Ensuite, le capteur de lumière se calibra pendant quelques minutes sur la lumière ambiante avant d'adapter le luminaire à l'intensité de la lumière ambiante.

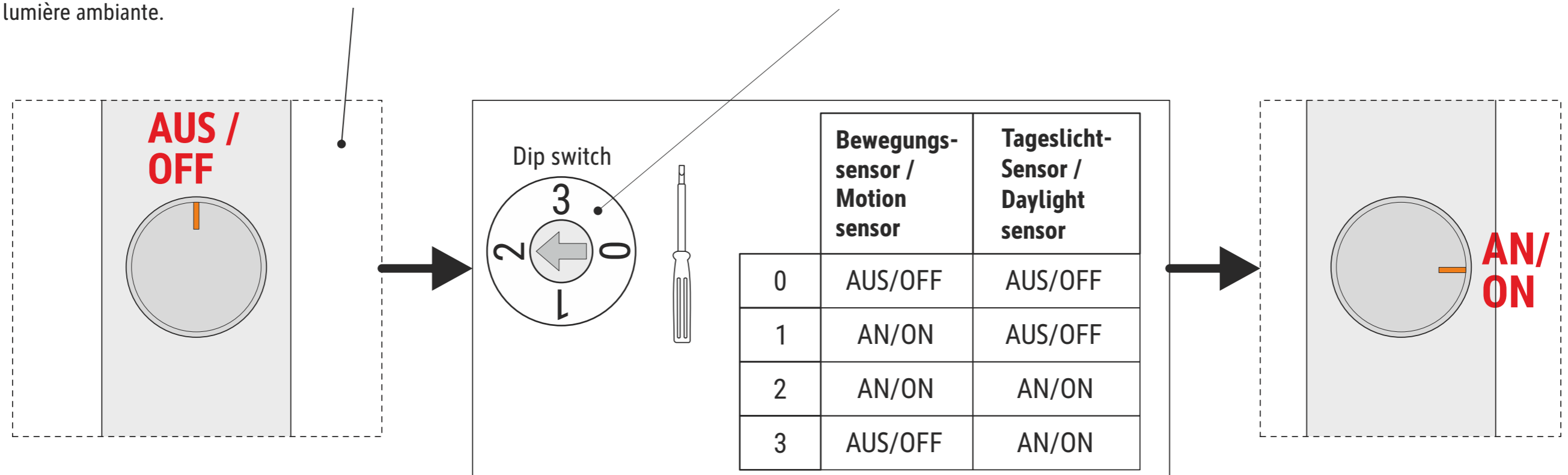

A

Bewegungssensor / Motion Sensor

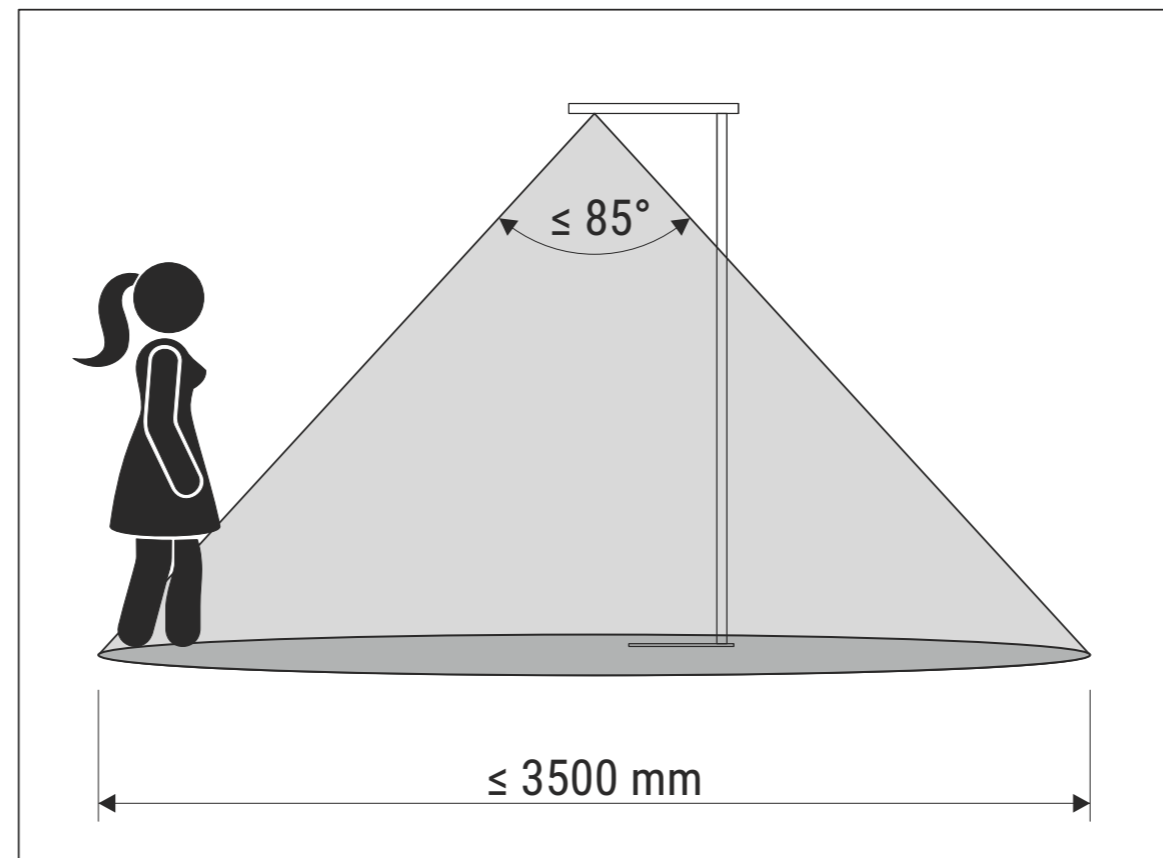
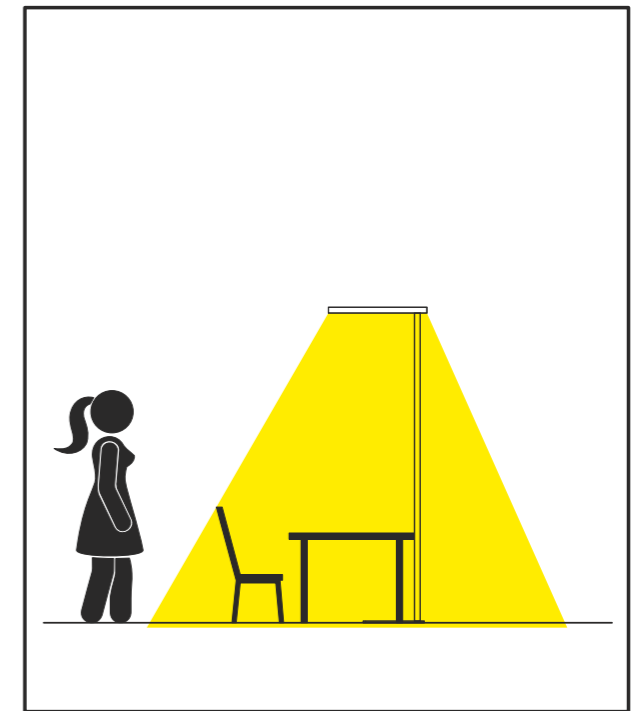
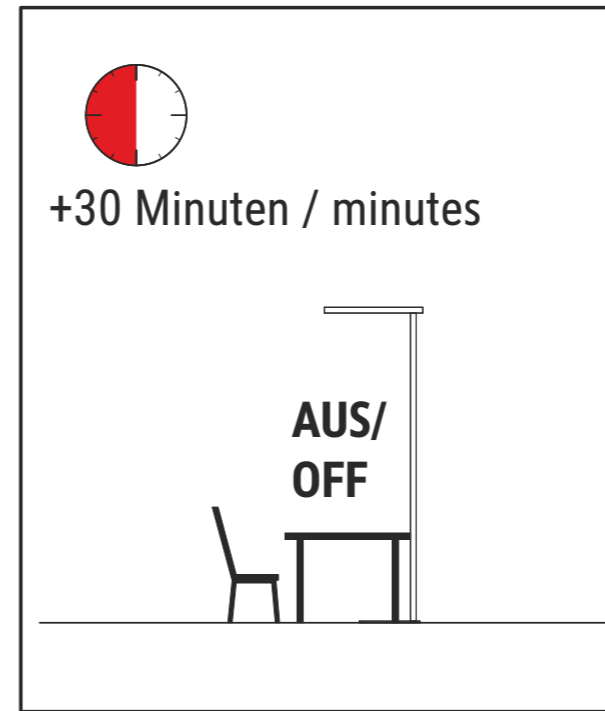
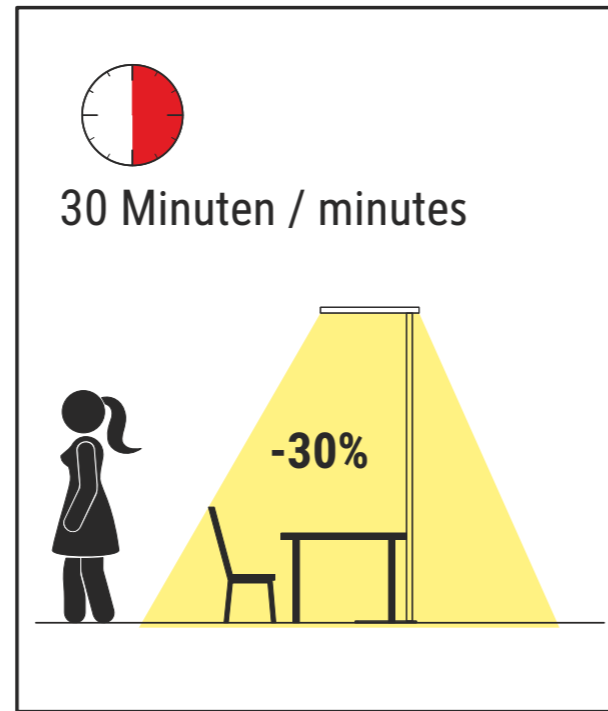
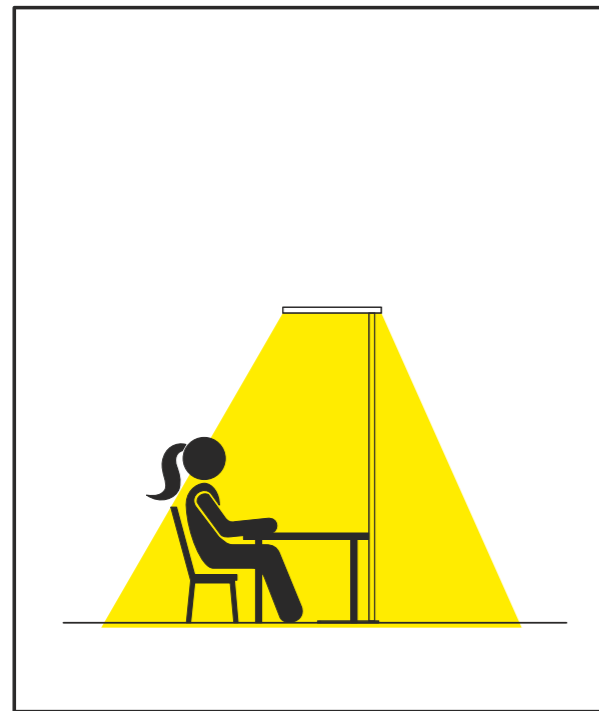

B

Tageslicht-Sensor / Daylight Sensor

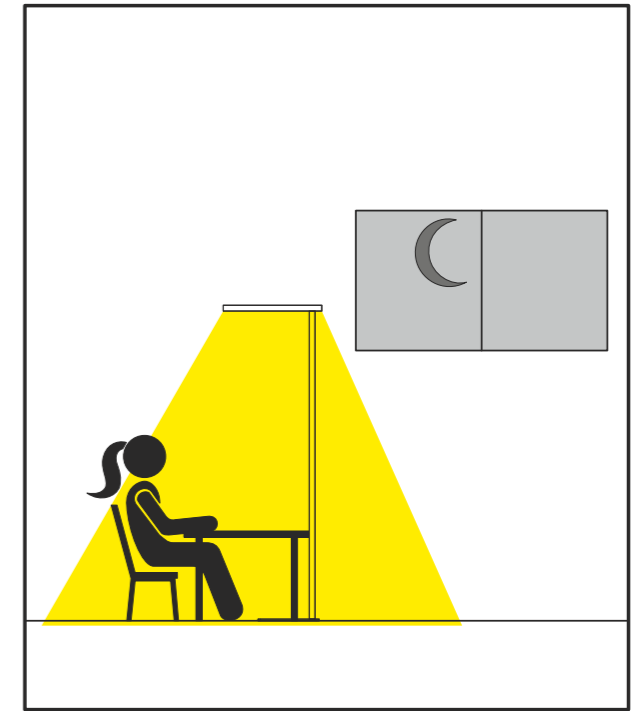
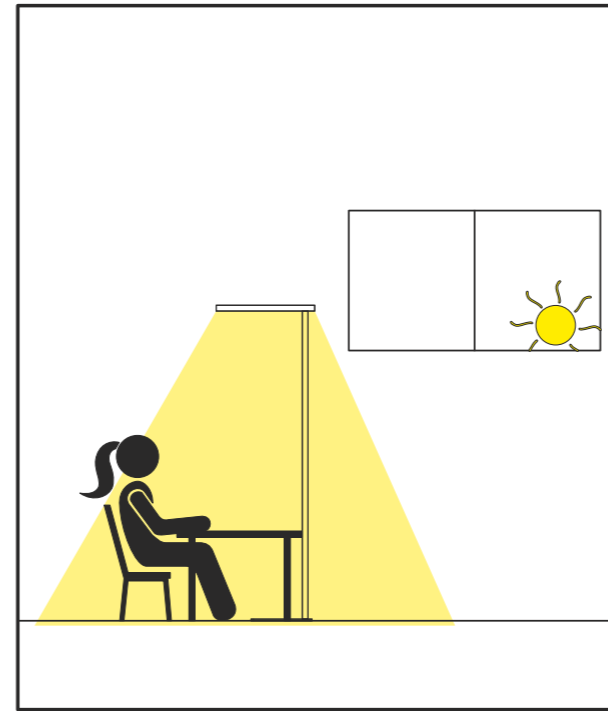
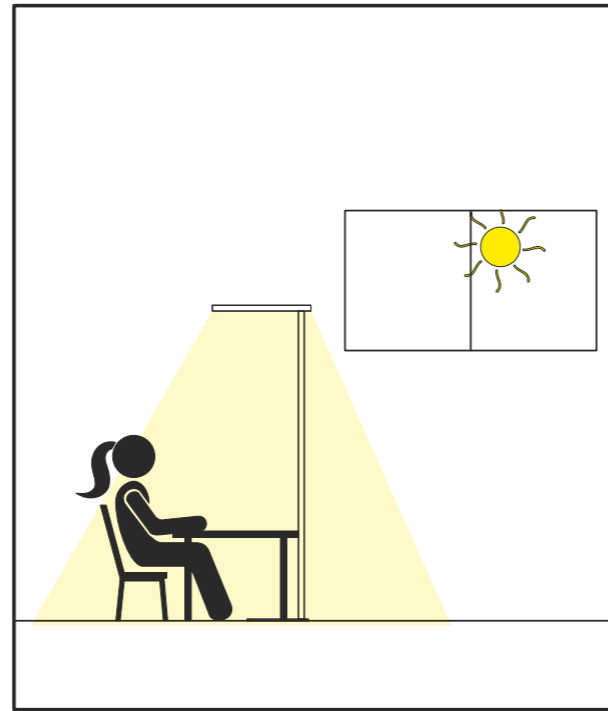
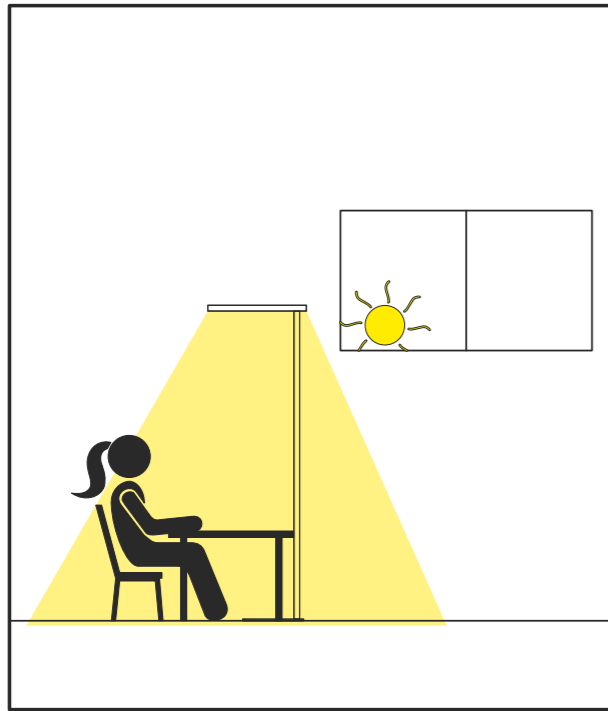

Art.-No.: 8258309.210
Art.-No.: 8258609.220
Art.-No.: 8258609.225

Art.-No.:
8258309.205A

2 x Art.-No.:
8258309.200A

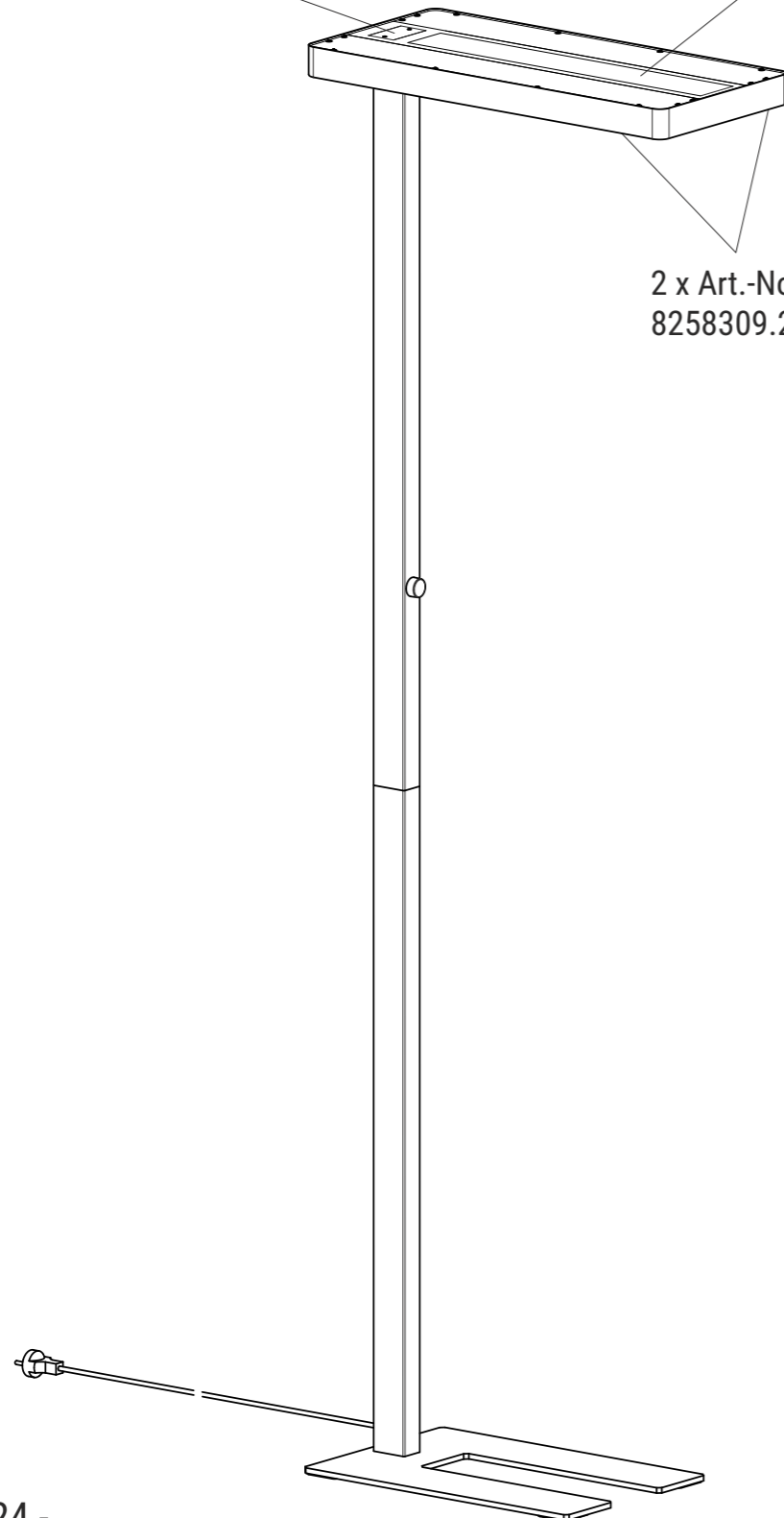

Ersatzteile (spare parts):

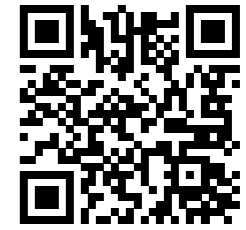

Art.-No.: 8258309.205A



Art.-No.: 8258309.210



Art.-No.: 8258609.220



Art.-No.: 8258609.225

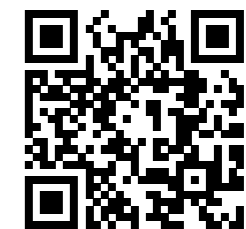

Art.-No.: 8258309.200A

DE:

Dieses Produkt enthält zwei Lichtquellen der Energieeffizienzklasse < C > (Art.-No.: 8258309.200A)
Dieses Produkt enthält eine Lichtquelle der Energieeffizienzklasse < C > (Art.-No.: 8258309.205A)

BG:

Този продукт съдържа два светлинни източника от клас на енергийна ефективност < C > (Art.-No.: 8258309.200A)
Този продукт съдържа един светлинен източник от клас на енергийна ефективност < C > (Art.-No.: 8258309.205A)

CZ:

Tento výrobek obsahuje dva světelné zdroje s třídy energetické účinnosti < C > (Art.-No.: 8258309.200A)
Tento výrobek obsahuje světelný zdroj s třídou energetické účinnosti < C > (Art.-No.: 8258309.205A)

DK:

Dette produkt indeholder to lyskilder i energieeffektivitetsklasse < C > (Art.-No.: 8258309.200A)
Dette produkt indeholder en lyskilde i energieeffektivitetsklasse < C > (Art.-No.: 8258309.205A)

ES:

Este producto contiene dos fuentes luminosas de la clase de eficiencia energética < C > (Art.-No.: 8258309.200A)
Este producto contiene una fuente luminosa de la clase de eficiencia energética < C > (Art.-No.: 8258309.205A)

EE:

Nimetatud toode sisaldab kahte energiatõhususe klassi < C > kuuluvat valgusallikat (Art.-No.: 8258309.200A)
Nimetatud toode sisaldab energiatõhususe klassi < C > kuuluvat valgusallikat (Art.-No.: 8258309.205A)

FI:

Tämä tuote sisältää kaksi valonlähdetä, joiden energiatehokkuusluokka on < C > (Art.-No.: 8258309.200A)
Tämä tuote sisältää valonlähteen, jonka energiatehokkuusluokka on < C > (Art.-No.: 8258309.205A)

FR:

Ce produit contient deux sources lumineuses de classe d'efficacité énergétique < C > (Art.-No.: 8258309.200A)
Ce produit contient une source lumineuse de classe d'efficacité énergétique < C > (Art.-No.: 8258309.205A)

GB:

This product contains two light sources of energy efficiency class < C > (Art.-No.: 8258309.200A)
This product contains a light source of energy efficiency class < C > (Art.-No.: 8258309.205A)

GR:

Αυτό το προϊόν περιέχει δύο πηγές φωτός με κλάση ενεργειακής απόδοσης < C > (Art.-No.: 8258309.200A)
Αυτό το προϊόν περιέχει μια πηγή φωτός με κλάση ενεργειακής απόδοσης < C > (Art.-No.: 8258309.205A)

HR:

Ovaj proizvod sadrži dva izvora svjetlosti s klasom energetske učinkovitosti < C > (Art.-No.: 8258309.200A)
Ovaj proizvod sadrži izvor svjetlosti s klasom energetske učinkovitosti < C > (Art.-No.: 8258309.205A)

HU:

Ez a termék két darab, < C > energiahatékonysági osztályba sorolt fényforrást tartalmaz (Art.-No.: 8258309.200A)
Ez a termék egy darab, < C > energiahatékonysági osztályba sorolt fényforrást tartalmaz (Art.-No.: 8258309.205A)

IT:

Questo prodotto contiene due sorgenti luminose di classe di efficienza energetica < C > (Art.-No.: 8258309.200A)
Questo prodotto contiene una sorgente luminosa di classe di efficienza energetica < C > (Art.-No.: 8258309.205A)

LT:

Šiame gaminyje yra du šviesos šaltiniai, kurių energijos vartojimo efektyvumo klasė yra < C > (Art.-No.: 8258309.200A)
Šiame gaminyje yra šviesos šaltinis, kurio energijos vartojimo efektyvumo klasė yra < C > (Art.-No.: 8258309.205A)

LV:

Šis ražojums satur divus gaismas avotus, kura energoefektivitātes klase ir < C > (Art.-No.: 8258309.200A)
Šis ražojums satur gaismas avotu, kura energoefektivitātes klase ir < C > (Art.-No.: 8258309.205A)

NL:

Dit product bevat twee lichtbronnen met energie-efficiëntieklasse < C > (Art.-No.: 8258309.200A)
Dit product bevat een lichtbron van energie-efficiëntieklasse < C > (Art.-No.: 8258309.205A)

NO:

Dette produktet inneholder to lyskilder i energiklasse < C > (Art.-No.: 8258309.200A)
Dette produktet inneholder en lyskilde i energiklasse < C > (Art.-No.: 8258309.205A)

PL:

Ten produkt zawiera dwa źródła światła o klasie efektywności energetycznej < C > (Art.-No.: 8258309.200A)
Ten produkt zawiera źródło światła o klasie efektywności energetycznej < C > (Art.-No.: 8258309.205A)

PT:

Este produto contém duas fontes de luz da classe de eficiência energética < C > (Art.-No.: 8258309.200A)
Este produto contém uma fonte de luz da classe de eficiência energética < C > (Art.-No.: 8258309.205A)

RO:

Acest produs conține două surse de lumină din clasa de eficiență energetică < C > (Art.-No.: 8258309.200A)
Acest produs conține o sursă de lumină din clasa de eficiență energetică < C > (Art.-No.: 8258309.205A)

RS:

Ovaj proizvod sadrži dva izvora svetlosti sa klasom energetske efikasnosti < C > (Art.-No.: 8258309.200A)
Ovaj proizvod sadrži izvor svetlosti sa klasom energetske efikasnosti < C > (Art.-No.: 8258309.205A)

SE:

Denna produkt innehåller två ljuskällor i energieffektivitetsklass < C > (Art.-No.: 8258309.200A)
Denna produkt innehåller en ljuskälla med energieffektivitetsklass < C > (Art.-No.: 8258309.205A)

SK:

Tento výrobek obsahuje dva svetelné zdroje triedy energetickej účinnosti < C > (Art.-No.: 8258309.200A)
Tento výrobek obsahuje svetelný zdroj triedy energetickej účinnosti < C > (Art.-No.: 8258309.205A)

SI:

Ta izdelek vsebuje dva svetlobna vira razreda energijske učinkovitosti < C > (Art.-No.: 8258309.200A)
Ta izdelek vsebuje svetlobni vir razreda energijske učinkovitosti < C > (Art.-No.: 8258309.205A)

TR:

Bu ürün, enerji verimliliği sınıfı < C > olan iki ışık kaynağı içerir (Art.-No.: 8258309.200A)
Bu ürün < C > enerji verimlilik sınıfında bir ışık kaynağı içerir (Art.-No.: 8258309.205A)

UA:

Цей виріб містить два джерела світла з класом енергоспоживання < C > (Art.-No.: 8258309.200A)
Цей виріб містить джерело світла з класом енергоспоживання < C > (Art.-No.: 8258309.205A)



Notice de conditionnement et d'élimination
Istruzioni di imballaggio e smaltimento
Опаковка и указание за изхвърляне



Garantiehinweis
Guarantee
Garantie

