

Technisches Datenblatt / Technical Datasheet

Art.-No. 63884



Abmaße Produkt: **L x B x H**
 48 x 160 x 86 mm
 Gewicht kompl.: 0,090 kg

Verp. Abmaße : L x B x H
 200 x 90 x 50 mm
 Gewicht kompl.: 0,121 kg



• Lieferung **ohne** Stifte

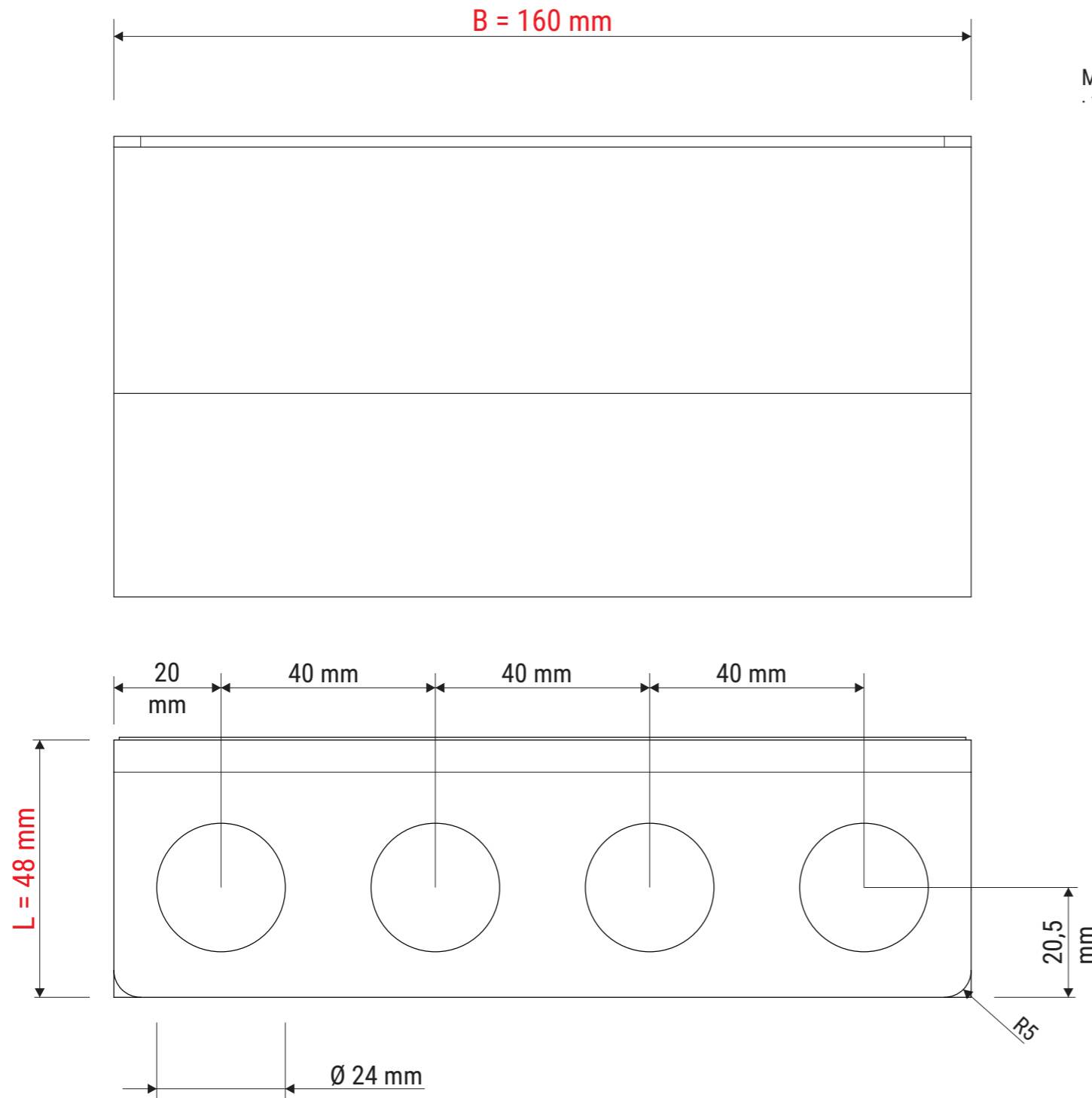

Magnetband
 · 155 x 25 x 2 mm

