

Technisches Datenblatt / Technical Datasheet

Art.-No. 82575

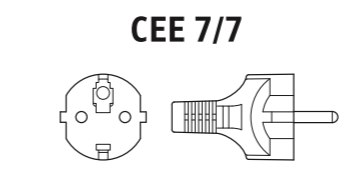
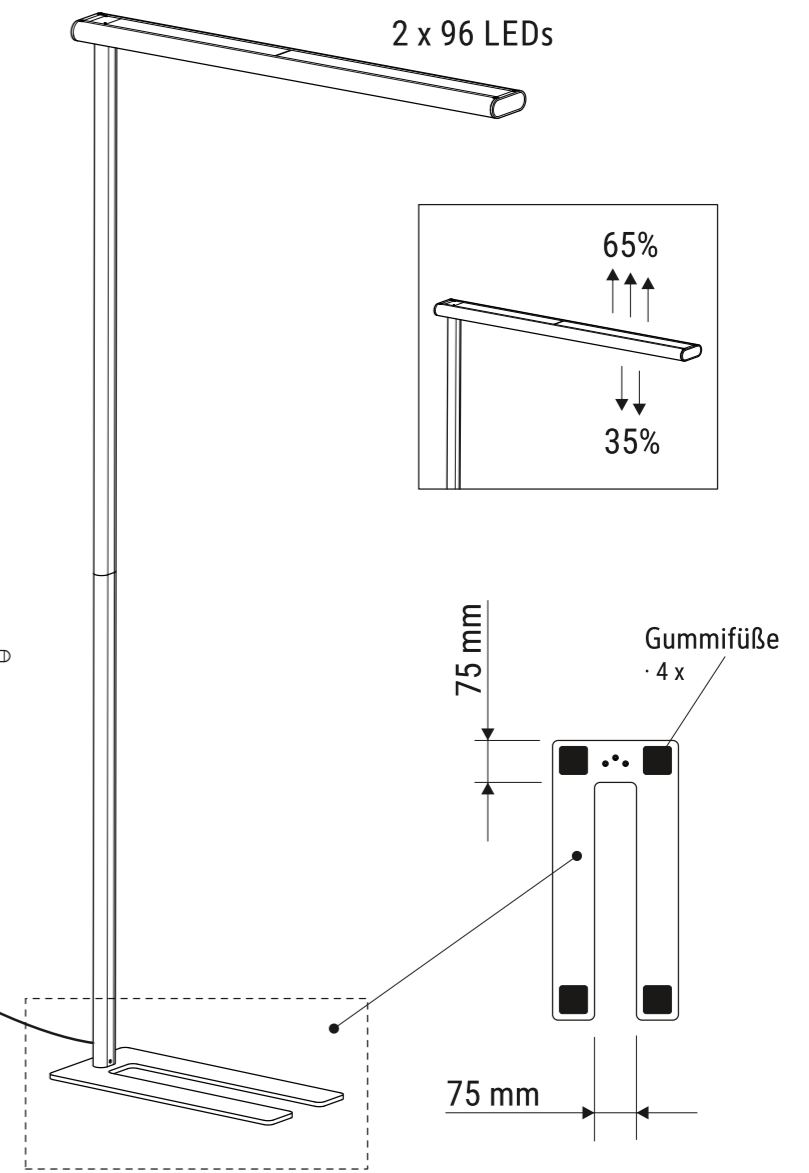
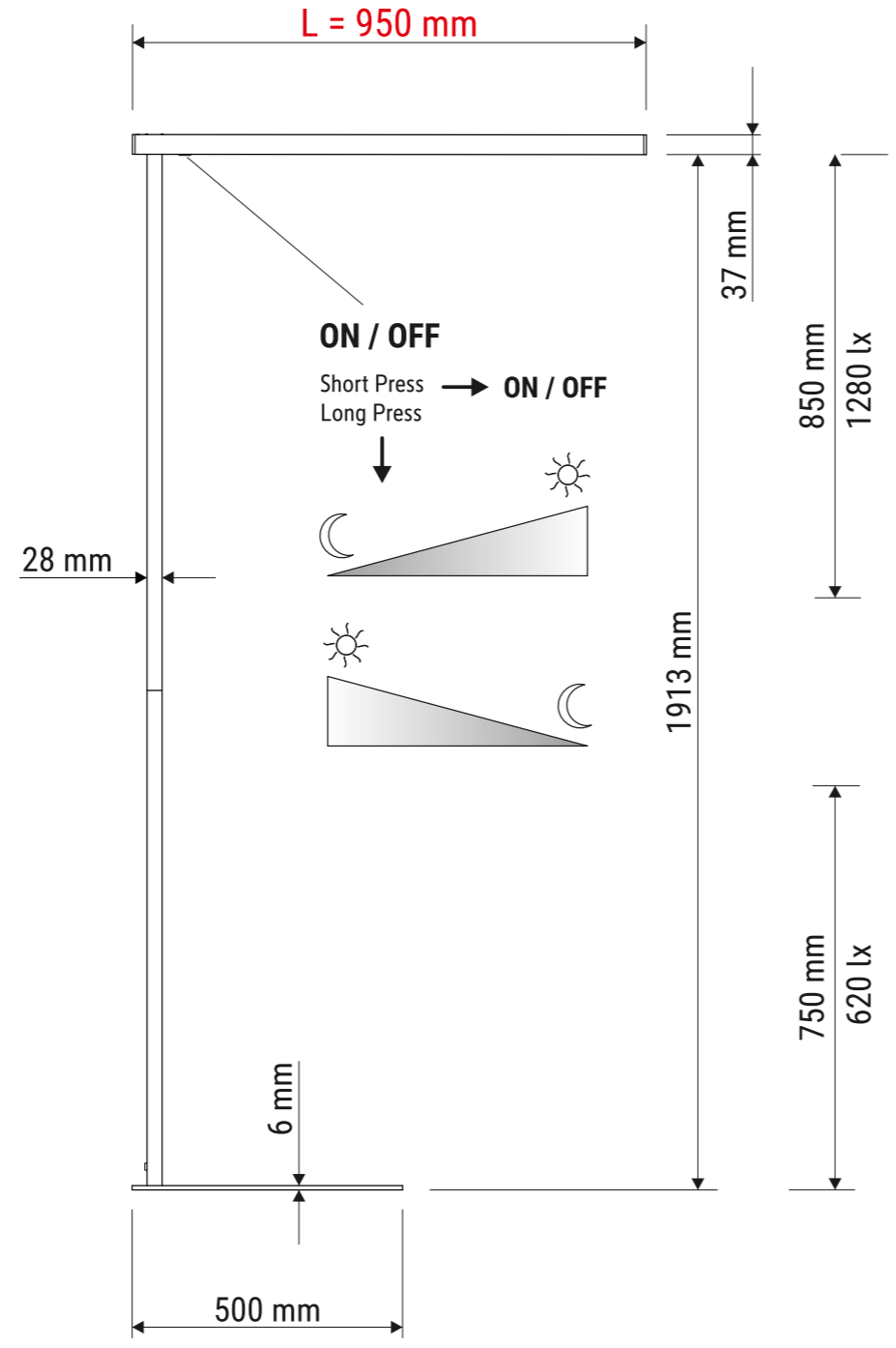
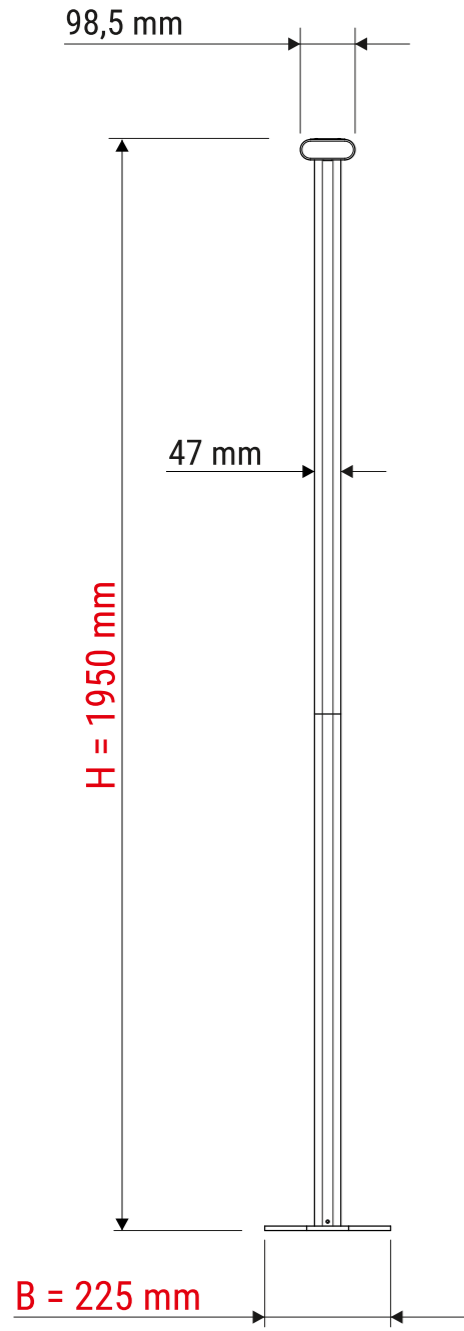
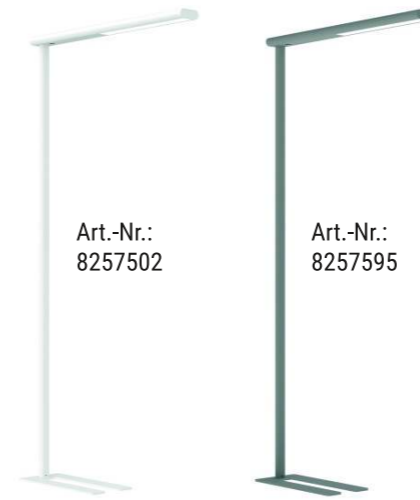

200-240V~
50/60 Hz
51 W
Schutzklasse: I

ca. 1,80 m

AbmaÙe Produkt: L x B x H
950 x 225 x 1950 mm
Gewicht: 7,446 kg

Verp. AbmaÙe : L x B x H
1205 x 320 x 130 mm
Gewicht kompl.: 9,371 kg