

Instructions for use



Table of Contents

1. General product information	3
1.1 Product description	3
1.2 Product	3
1.3 Scope of supply	3
1.4 Area of application	3
2. Important information for safe use	4
2.1 Warranty	4
2.2 Completeness	4
2.3 Damage	4
2.4 Purposes of the system	4
2.4.1 Standards and directives	4
2.4.2 Intended use	4
2.4.3 Target group	4
2.5 Disposal	4
3. Safety instructions	5
3.1 Structure of the safety instructions	5
3.1.1 Identification of injury hazards	5
3.1.2 Identification of material damage	5
3.1.3 Identification of additional information	5
3.2 Pictograms supplementing the safety information	5
3.3 Pictograms on the lamp	5
3.4 Pictograms on the packaging	6
3.5 Overview of the most important safety instructions	6
4. Overview of abbreviations	10
5. Operation	11
5.1 Switching the electric torch on and off	11
5.2 Adjusting the light beam (zoom function)	11
5.3 Changing the batteries	12
5.4 Cleaning	12
5.5 Tests	13
5.6 Warranty	13
6. Technical data	14

1. General product information

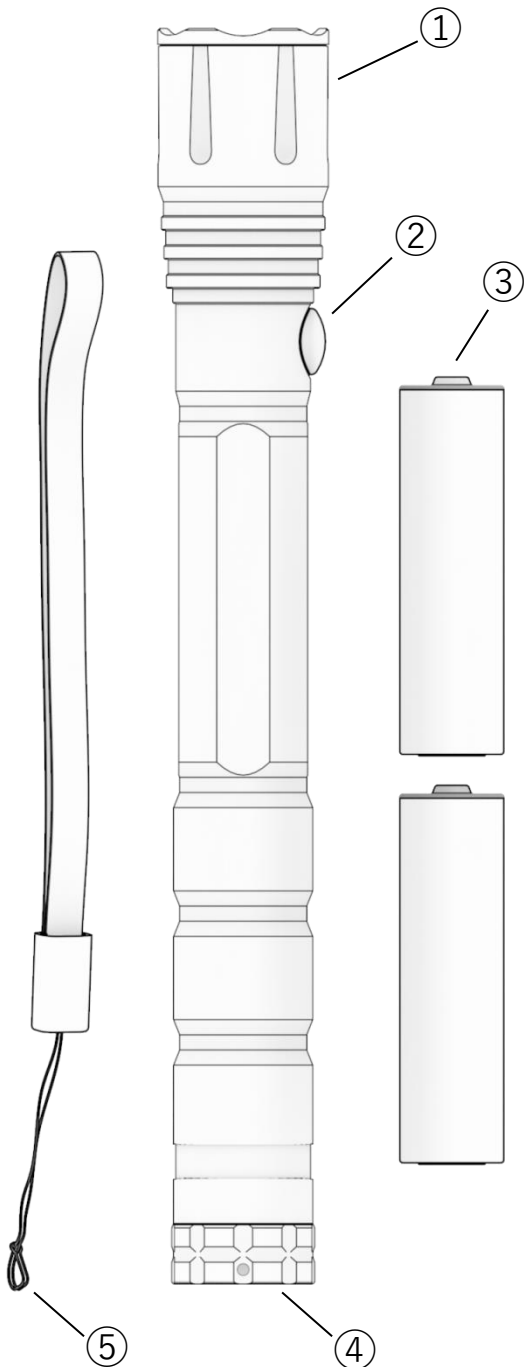

1.1 Product description

- ① Lamp head with adjustable light beam
- ② On/off push switch
- ③ Battery (Type AA)
- ④ Screw-off end cap
- ⑤ Hand strap

1.2 Product

Designation Electric torch MAULDion
Product no.: 81866

1.3 Scope of supply

Electric torch
2 batteries (Type AA)
Quick illustrated guide

1.4 Area of application

The electric torch is suitable for use outdoors and is splash-proof (IPX4)

2. Important information for safe use

2.1 Warranty

MAUL GmbH only guarantees the safety and proper functioning of the electric torch under the condition that:

- the electric torch is used and maintained exclusively for its intended use and in accordance with the specifications of these instructions for use
- only original spare parts and accessories approved by MAUL are used
- no modifications are made to the electric torch

2.2 Completeness

Before use, visually check the electric torch for completeness and for any possible damage

2.3 Damage

In case of damage or missing parts, please consult the point of sale.

2.4 Purposes of the system

2.4.1 Standards and directives

- The CE mark confirms compliance with the applicable standards and legal provisions

2.4.2 Intended use

- The electric torch is used to see and to be seen in the dark.
- The electric torch is suitable for use outdoors.
- Any use beyond the conditions specified above is regarded as improper use. The user is solely liable for damages resulting from improper use.

2.4.3 Target group

The electric torch is suitable for persons without disabilities who are over 14 years of age.

Persons with disabilities and children between the age of 6 and 13 may only use the electric torch with when accompanied or supervised by a parent or legal guardian or by a caretaker.

2.5 Disposal

- Do not dispose of the electric torch and battery / rechargeable battery in domestic waste, but rather at the disposal point for the recycling of electrical and electronic devices in accordance with country-specific regulations. This device contains recyclable materials.
- Used batteries / rechargeable batteries must be handed over to local battery collection points or wherever batteries are sold in accordance with country-specific regulations.

3. Safety instructions

DANGER

WARNING

CAUTION

PLEASE NOTE

NOTE



3.1 Structure of the safety instructions

In these instructions for use, important instructions are identified by pictograms and signal words.

3.1.1 Identification of injury hazards

Signal words such as DANGER, WARNING and CAUTION refer to the classification of a potential injury hazard.

DANGER indicates an immediately dangerous situation that, if not prevented, will result in death or serious injury.

WARNING indicates a potentially dangerous situation that, if not prevented, may result in death or serious injury.

CAUTION indicates a potentially dangerous situation that, if not prevented, may result in moderate or minor injury.

3.1.2 Identification of material damage

PLEASE NOTE indicates a potentially dangerous situation that, if not prevented, may result in material damage.

3.1.3 Identification of additional information

NOTE provides you with additional information and helpful tips for the safe and efficient use of the electric torch.

3.2 Pictograms supplementing the safety information

Risk of explosion: warning about the explosion of the battery / rechargeable battery caused by intense heat

Risk of glare: warning about glare caused by a light beam with high luminance

Follow the instructions for use: reminder to comply with these instructions for use

3.3 Pictograms on the lamp

Optical radiation: warning about potential damage to the retina caused by photobiological radiation

3. Safety instructions



3.4 Pictograms on the packaging

CE mark: confirms compliance with the applicable standards and legal provisions



3.5 Overview of the most important safety instructions

- The following safety instructions must be read carefully before using the electrical torch!
- If the torch is handed over to other persons, the instructions for use must be provided with it.
- If warnings or warning symbols are applied to the product, they may not be removed.

HEALTH HAZARD

WARNING

RISK OF ACCIDENT / INJURY FOR CHILDREN

Do not place the electric torch in the hands of children or persons hindered by medication, drugs, or physical or mental disabilities, as there is a risk of damage to the eyes and a risk of accidents.

For this reason:

- Do not allow children to play with the torch.
- Persons with disabilities should only use the lamp under the supervision or guidance of a responsible person.

WARNING



RISK OF GLARE

The strong glare effect of the lamp may cause a temporary impairment of eyesight and after-images that may lead to irritations, impairments or accidents.

For this reason:

- Never look directly into the light beam or direct the light into the eyes of other persons, and do not examine the pupils.
- Do not direct the light beam onto persons or animals, as they may be blinded.
- Do not use any strongly focussing instruments to view the light beam.
- Do not use multiple electric torches at the same time, as this increases the optical radiation and thus the risk of retinal damage.
- Instruct commercial users or users in the public sector in the applicable laws and regulations.

What should I do:

→ If a light beam strikes your eyes, deliberately close them and move your head away from the light beam.

3. Safety instructions

CAUTION

RISK OF INJURY

Do not use the electric torch or accessories if they are damaged, as they pose a risk of injury.

For this reason:

- Put damaged parts out of operation and replace them or have them repaired properly

CAUTION



PHOTOBIOLOGICAL SAFETY (EYE SAFETY)

According to the standard IEC 62471, the electric torch is classified in Risk Group 2 (moderate risk) and therefore goes beyond the "Free Group". There is a risk of retinal damage from optical radiation (blue light 400 nm to 780 nm).

NOTE

ELECTROMAGNETIC COMPATIBILITY

The electric torch meets the requirements of Directive 2014/30/EU with respect to electromagnetic compatibility.

MODIFICATIONS / REPAIRS

CAUTION

DO NOT MAKE ANY MODIFICATIONS / REPAIRS

It is not allowed to make repairs, add-ons or modifications to the torch, as this may result in damage to the electric torch or put persons at risk.

For this reason:

- Do not damage, modify or short-circuit the electric torch, or use it as a tool.
- Do not open the electric torch (LED cannot be replaced).
- Never perform any repairs yourself. Bring the electric torch to the seller / retailer.

3. Safety instructions

BATTERIES AND RECHARGEABLE BATTERIES

WARNING



RISK OF EXPLOSION OR ACID BURN

Intense heat may cause batteries / rechargeable batteries to explode.

Leaking battery acid may cause acid burns.

For this reason: Batteries and rechargeable batteries

- may not be exposed to direct solar radiation / intense heat for an extended period,
- may not be heated or thrown in the fire and heat accumulation in the electric torch must be prevented e.g. by covering,
- may not be thrown in the water or left in the rain,
- may not be ingested,
- may not be opened, damaged or short-circuited,
- may only be charged if they are properly marked,
- may not be stored within reach of children,
- may only be inserted according to the marks (+/-) shown in the battery compartment,
- must be removed from the electric torch if not used for an extended period or if they are discharged

What should I do:

In case of leaking batteries, put cloths underneath the batteries and prevent the battery fluid from contacting the skin, eyes and mucous membranes. In case of contact, immediately flush the affected spots with plenty of clear water and consult a physician.

PLEASE NOTE

CHANGING THE BATTERIES / RECHARGEABLE BATTERIES

- Store batteries / rechargeable batteries in a clean, dry place at a temperature between -10°C and +25°C.
- Only insert batteries / rechargeable batteries according to the mark (+/-).
- If necessary, clean the contacts of the batteries / rechargeable batteries or the electric torch prior to insertion.
- Only use the prescribed batteries / rechargeable batteries.
- Only use batteries / rechargeable batteries of the same make.
- Never use new and used batteries / rechargeable batteries together.
- Always change all batteries / rechargeable batteries at the same time.
- Do not store batteries / rechargeable batteries within reach of children.
- Observe the instructions of the manufacturer of the battery charger when charging batteries.

3. Safety instructions

PLEASE NOTE

MALFUNCTIONS OF THE ELECTRIC TORCH

Always check the functioning of the electric torch prior to use and, to be safe, take along a spare electric torch and spare batteries / rechargeable batteries. If the electric torch does not function or does not function correctly, proceed as follows:

- Check whether the batteries / rechargeable batteries were inserted with the correct polarity (+/-) and are functional.
- Check the contacts of the electric torch / batteries and clean if necessary.

What should I do:

→ In order to use all the functions again, insert new batteries / rechargeable batteries.

DISPOSAL / ENVIRONMENTAL PROTECTION

PLEASE NOTE

DISPOSAL / RECYCLING

Do not dispose of the electric torch and the batteries / rechargeable batteries in domestic waste. They must be disposed of according to the country-specific regulations. This device contains recyclable materials.

For this reason:

- Hand over the electric torch to a local collection point for the recycling of electric and electronic devices.
- Hand over used batteries / rechargeable batteries to the local battery collection point or wherever batteries / rechargeable batteries are sold.
- Separate packaging material and dispose of it properly.

4. Overview of abbreviations

The following abbreviations are used in these instructions:

LED > Light Emitting Diode

5. Operation

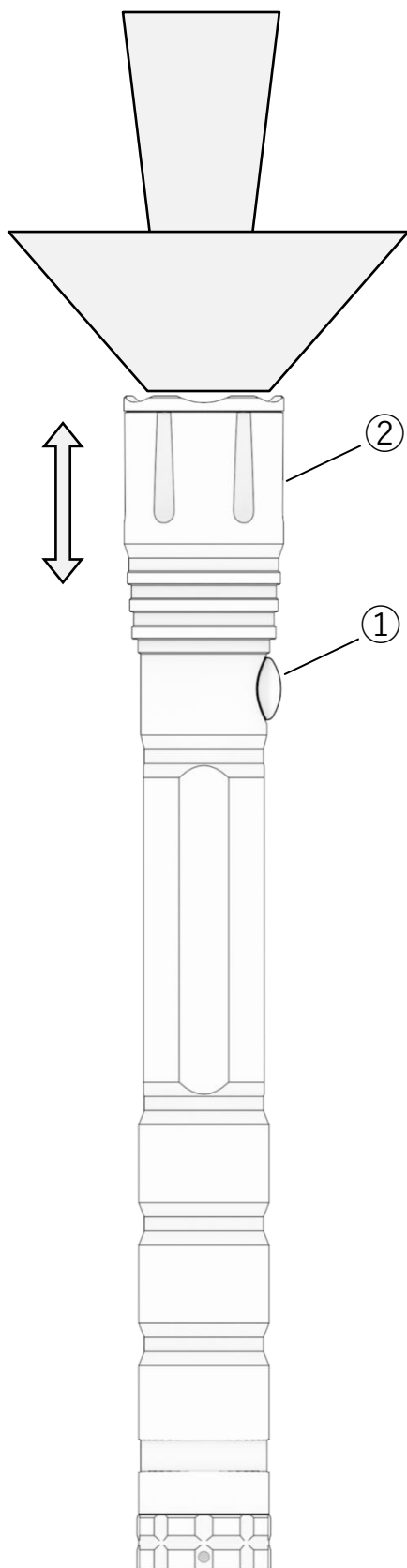

5.1 Switching the electric torch on and off

The electric torch can be switched on and off by pressing the push switch ①

5.2 Adjusting the light beam (zoom function)

1. Switch on the electric torch by firmly pressing the push switch ①
2. Slide the lamp head ② forwards (concentrated high beam)
3. Slide the lamp head ② backwards (scattered low beam)

5. Operation

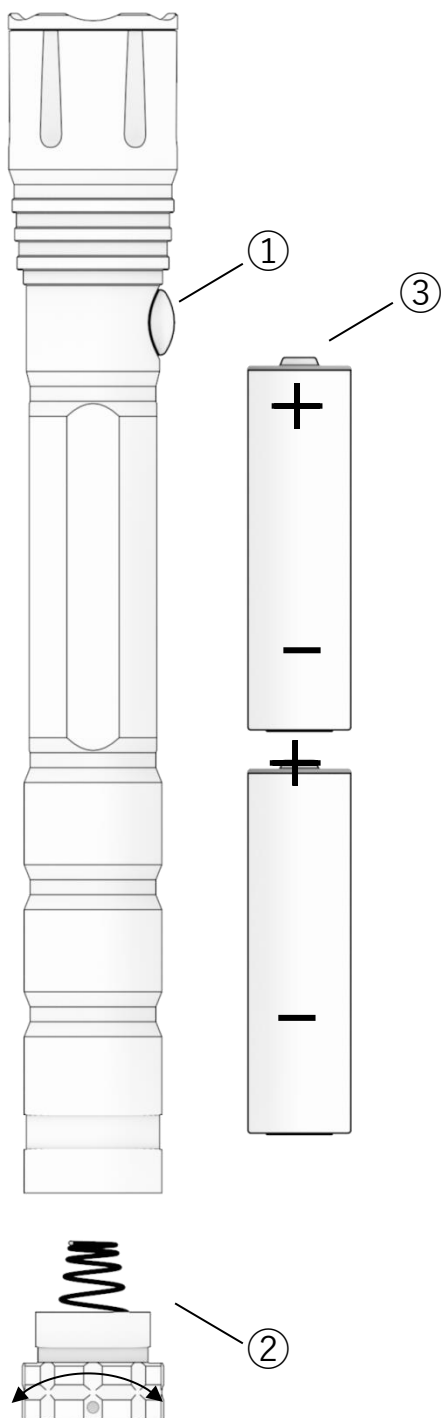

5.3 Changing the batteries

1. Press the switch ① to switch off the electric torch
2. Screw off the end cap ② of the electric torch in a counter-clockwise direction
3. Remove the batteries ③

CAUTION



RISK OF EXPLOSION AND FIRE

Always insert batteries with the correct polarity

Note the +/- mark

4. Insert new batteries ③ with the correct polarity
5. Screw on the end cap ② in a clockwise direction

PLEASE NOTE

The electric torch may only be operated with standard 1.5 V Type AA batteries.

5.4 Cleaning

When cleaning, observe the following:

- Only clean the electric torch with a dry, lint-free cloth
- Do not use any aggressive chemicals or abrasive cleaners

5. Operation

5.5 Tests

Every product is subject to wear with time. Test the safety and functioning of the electric torch and the batteries annually or before each use.

PLEASE NOTE

REPLACE AND DISPOSE OF DAMAGED OR OLD BATTERIES.
DO NOT USE THE ELECTRIC TORCH AND ACCESSORIES AND
CONTACT THE SELLER / RETAILER.

5.6 Warranty

Our products are subject to a strict final quality control. Should this electric torch unexpectedly fail to function properly, please consult the seller / retailer.

PLEASE NOTE

IMPROPER REPAIRS

The device may only be repaired by an authorised service company, otherwise the statutory warranty becomes invalid.

6. Technical data

Designation	Value
LED	1 x Lumen
Length	170 mm
Head diameter	23 mm
Weight (without packaging and battery)	50 g
Batteries	2 x alkaline battery, Type AA, 1.5 V, 2300 mAh
Luminous flux *	39 lm
Luminous range *	71 m
Lighting duration **	6 h
Protection against water	IPX4

* Luminous flux (lumen) / maximum luminous range (metres) measured in the brightest setting when switching on the torch with new batteries. The values are average values that may deviate by + / - 20% depending on the LED and the battery.

** The lighting duration defines the duration measured 30 seconds after switching on the torch for the first time with new batteries to the time at which the luminosity reaches 10% of its initial value.