

Technisches Datenblatt / Technical Datasheet

Art.-No. 62630

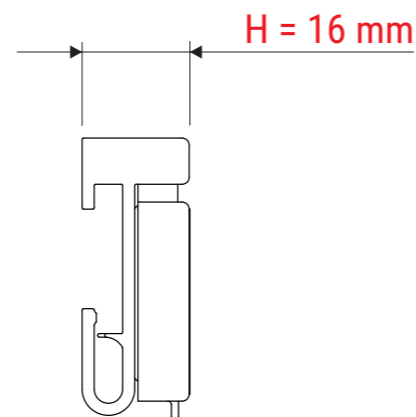

Vorderansicht

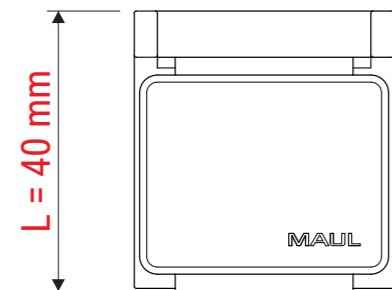
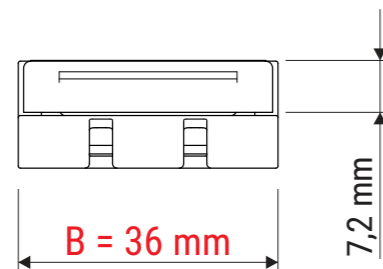

Rückansicht

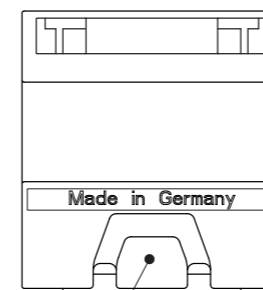

Haken

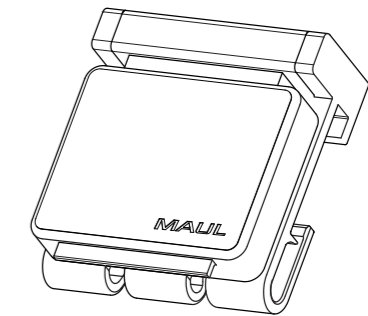

Magnetschnappautomatik

- Deckel aufklappen, Vorlage einschieben, Deckel schnappt durch Kontakt zu und hält fest

Ansicht von hinten

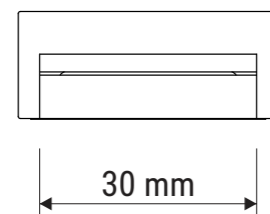

- Verschiebbar: Zur weiteren Bestückung der Planhalter-Schwenkarme

Abmaße Produkt: **L x B x H**
40 x 36 x 16 mm
Gewicht kompl.: 0,019 kg

Verp. Abmaße : L x B x H (10 Stck. im Karton)
185 x 80 x 17 mm
Gewicht kompl.: 0,206 kg

Technisches Datenblatt / Technical Datasheet
Art.-No. 62630



90° aufgeklappt

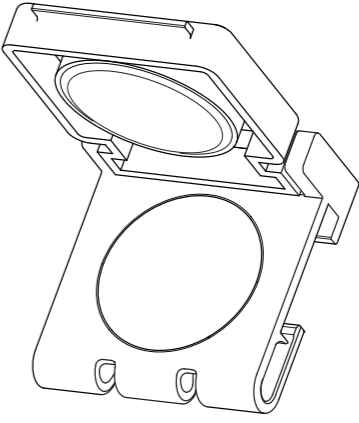
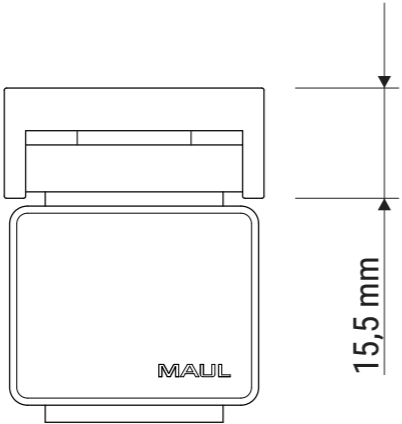
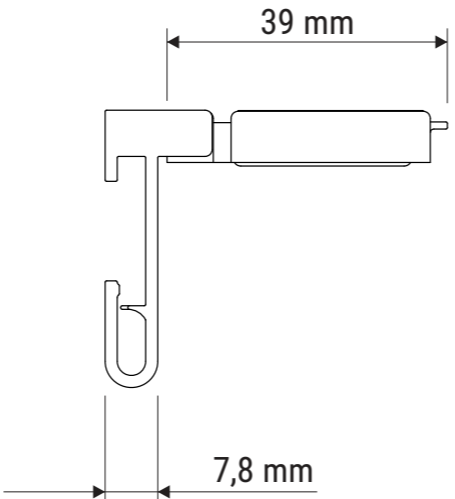
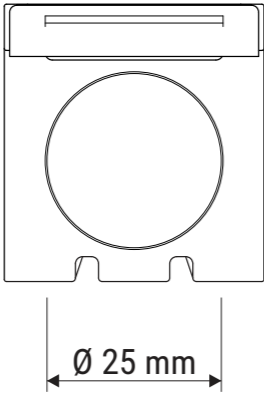

Technisches Datenblatt / Technical Datasheet

Art.-No. 62630



Magnet
· Ø 25 mm
· mit Schutzlack, für unbeschädigtes Herausziehen der Vorlage

komplett aufgeklappt

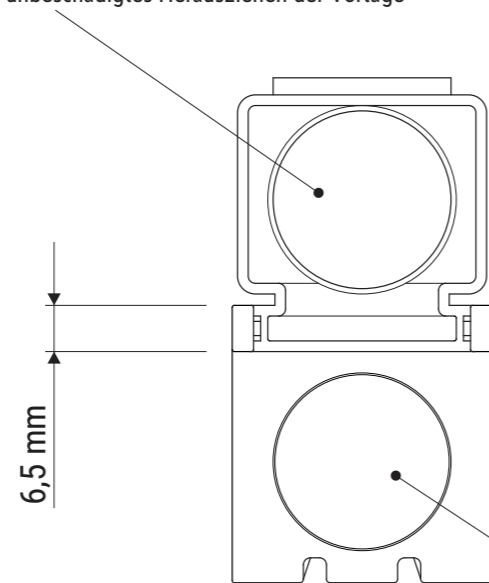

Metallplättchen
· Ø 25 mm
· 0,5 mm dick

