

Technisches Datenblatt / Technical Datasheet

Art.-No. 23393

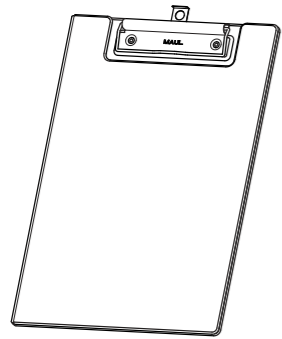

Klemmweite: ca. 8 mm

Vorderseite

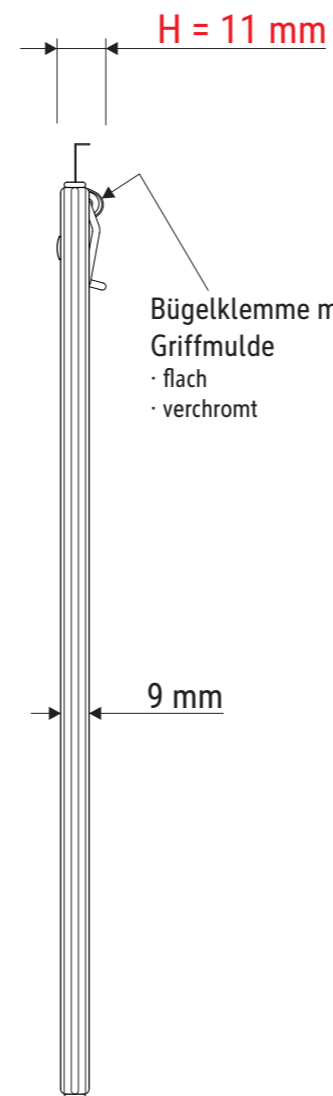
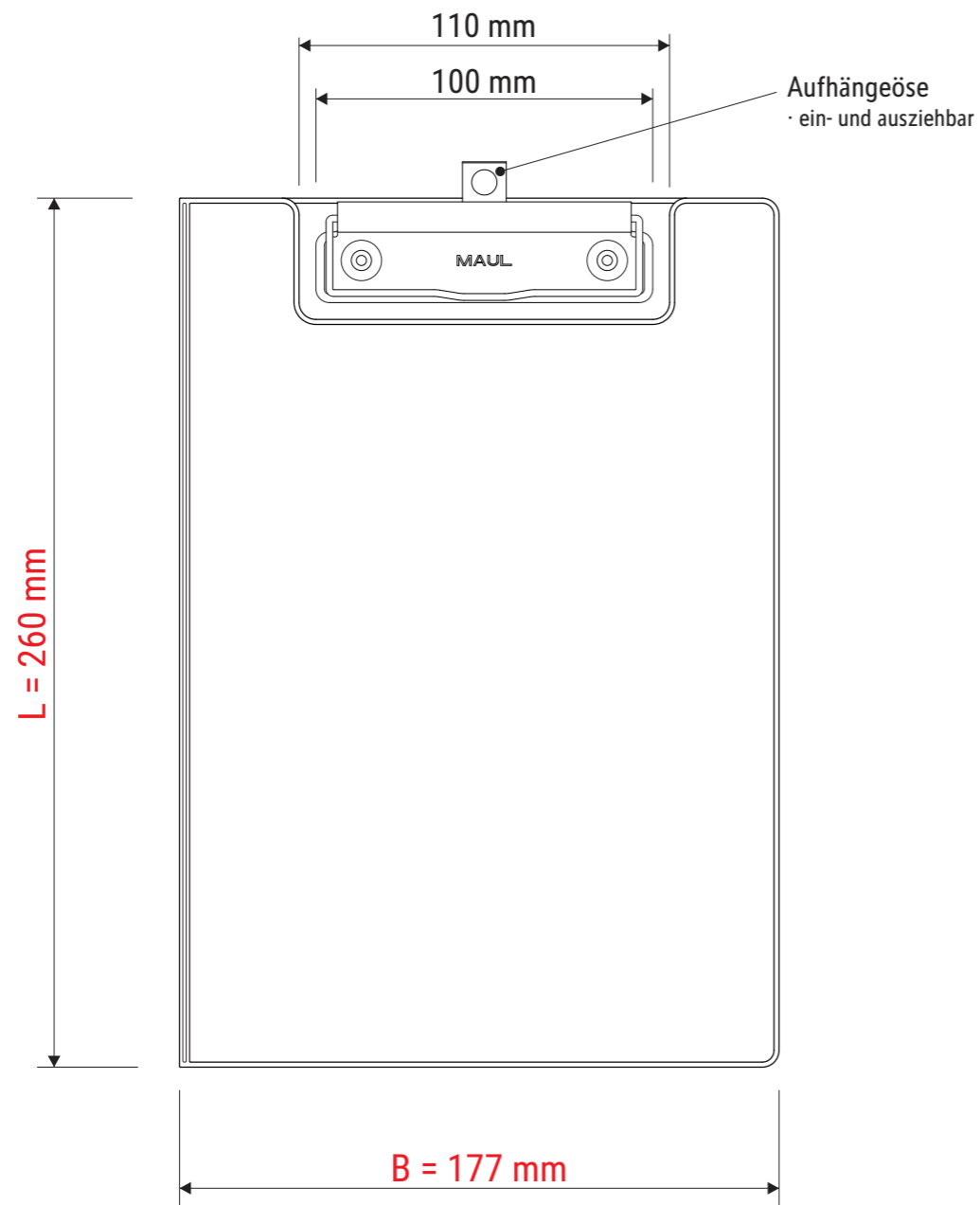

Rückseite

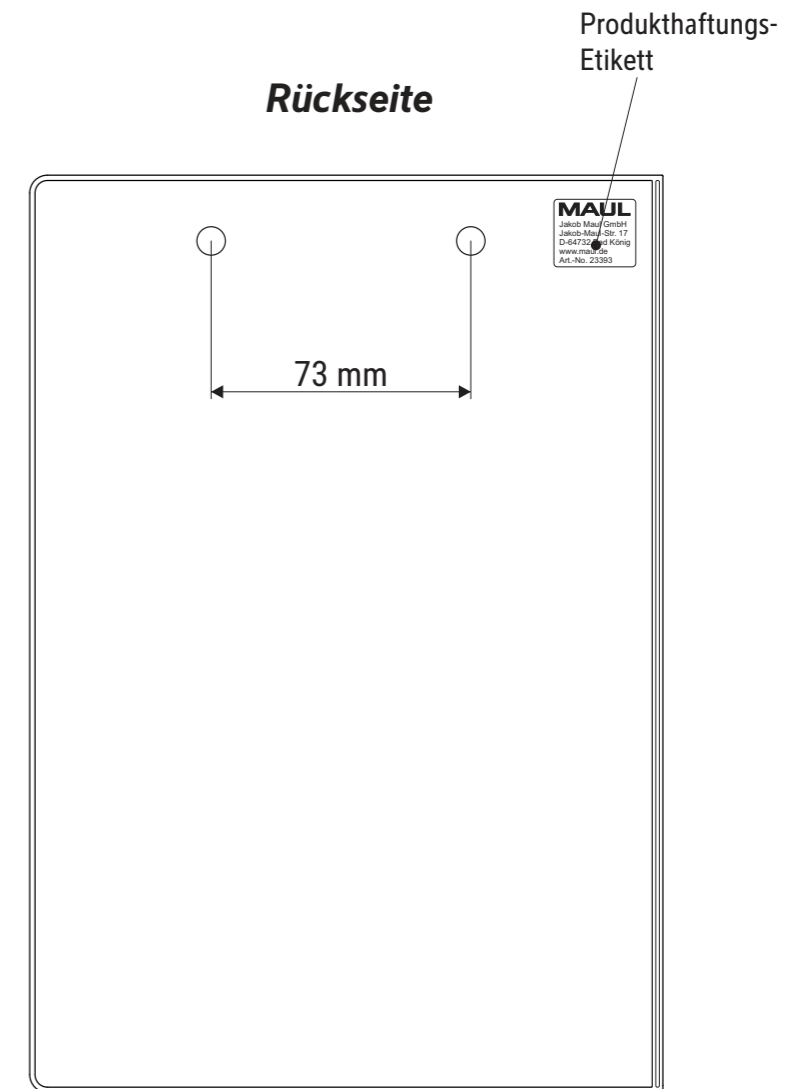

Abmaße Produkt: L x B x H
260 x 177 x 11 mm
Gewicht kompl.: 0,150 kg

Verp. Abmaße: L x B x H (1 Stck.)
260 x 177 x 12 mm
Gewicht kompl.: 0,155 kg

Technisches Datenblatt / Technical Datasheet

Art.-No. 23393

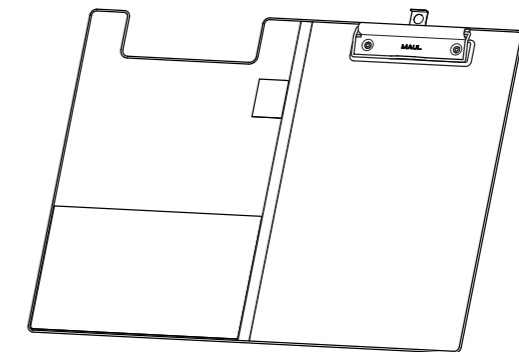

Schreibmappe aufgeklappt

Mappe
 · aus Karton
 · Karton 2 mm stark
 · mit Folienüberzug

Stifteschlaufe
 · 30 x 21 mm

Klemmer
 · auf Grundplatte genietet

