

# Technisches Datenblatt / Technical Datasheet

## Art.-No. 16230

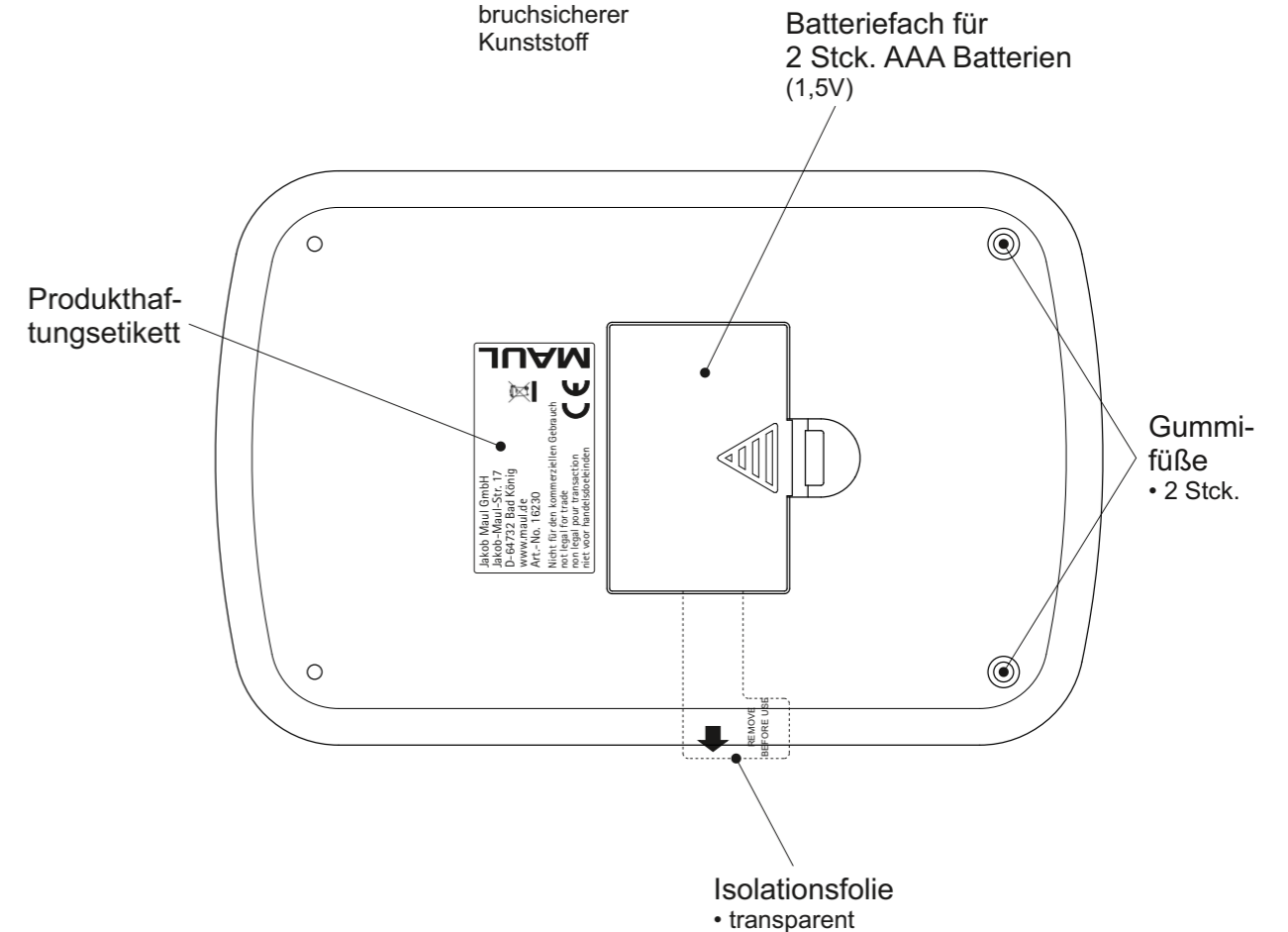
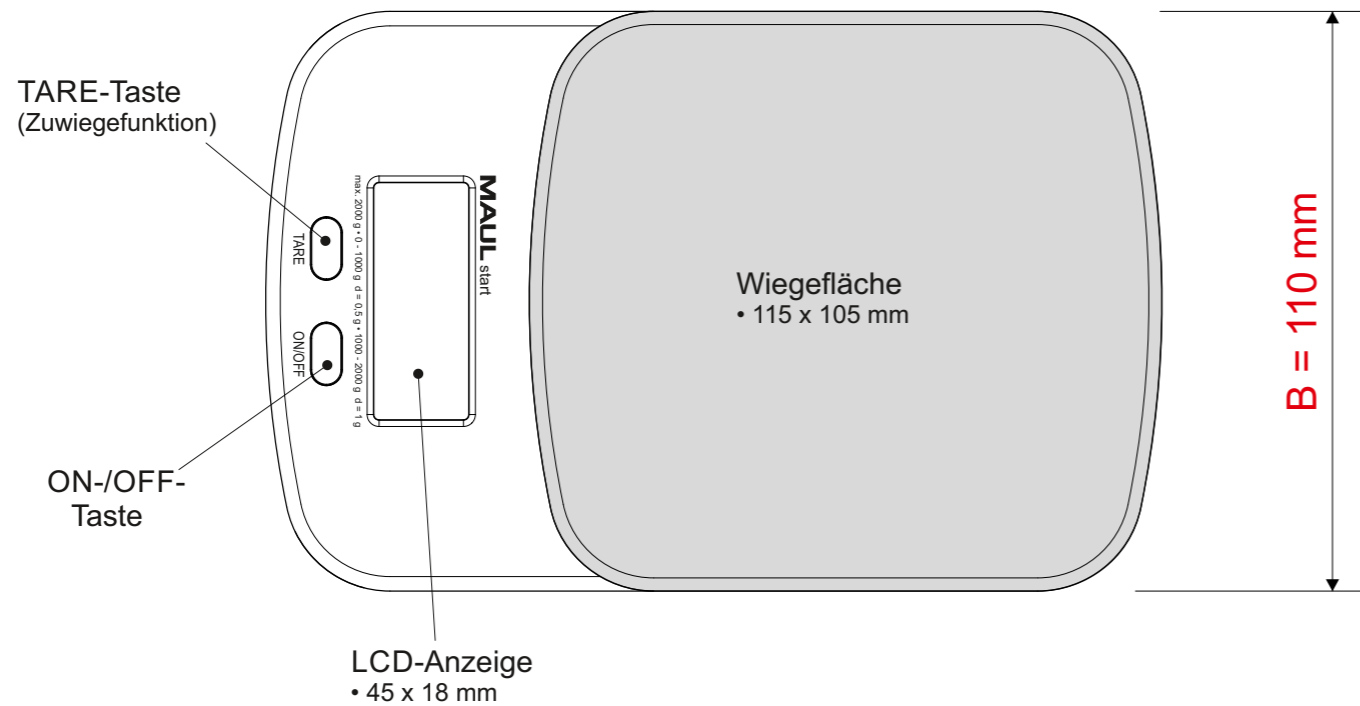
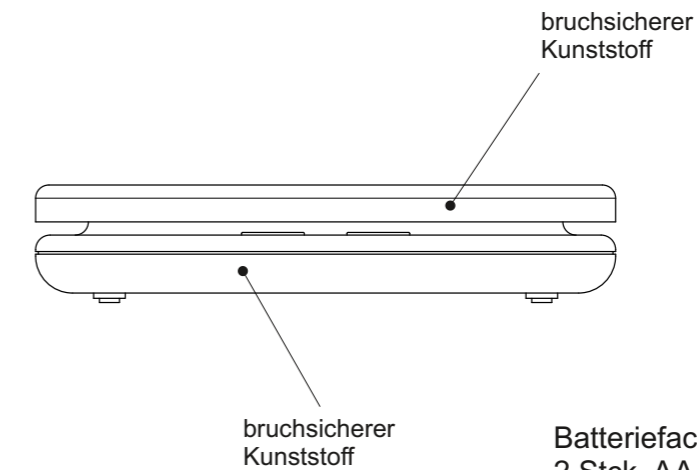
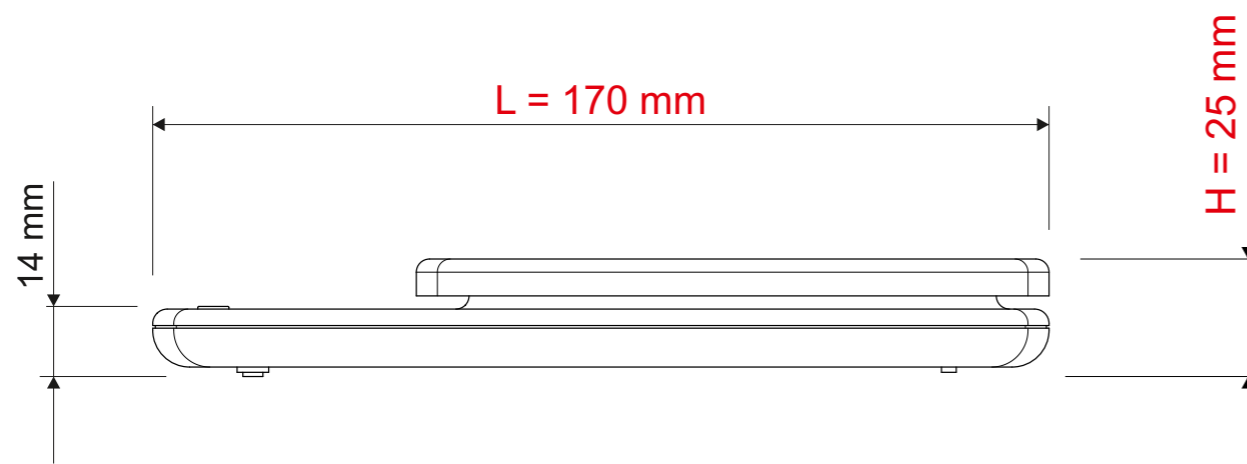

- Tragkraft 2000 g
- Teilung 0 - 1000 g d = 0,5 g / 1000 - 2000 g d = 1 g
- Mindestlast 1 g
- Benutzerkalibrierung möglich
- Abschaltautomatik
- automatische Nullstellung

AbmaÙe Produkt: **L x B x H**  
170 x 110 x 25 mm  
Gewicht kompl.: 0,152 kg

Verp. AbmaÙe : L x B x H  
185 x 127 x 39 mm  
Gewicht kompl.: 0,249 kg