

Technisches Datenblatt / Technical Datasheet

Art.-No. 61663

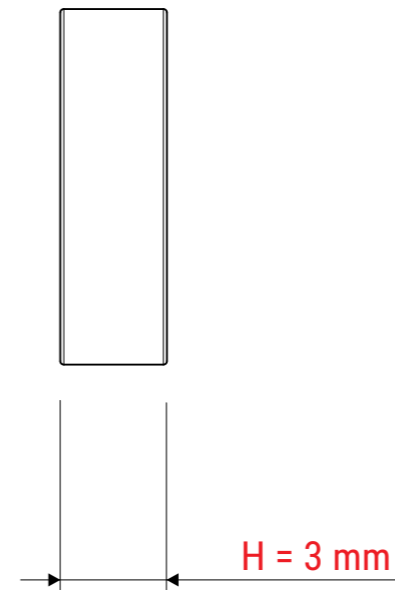
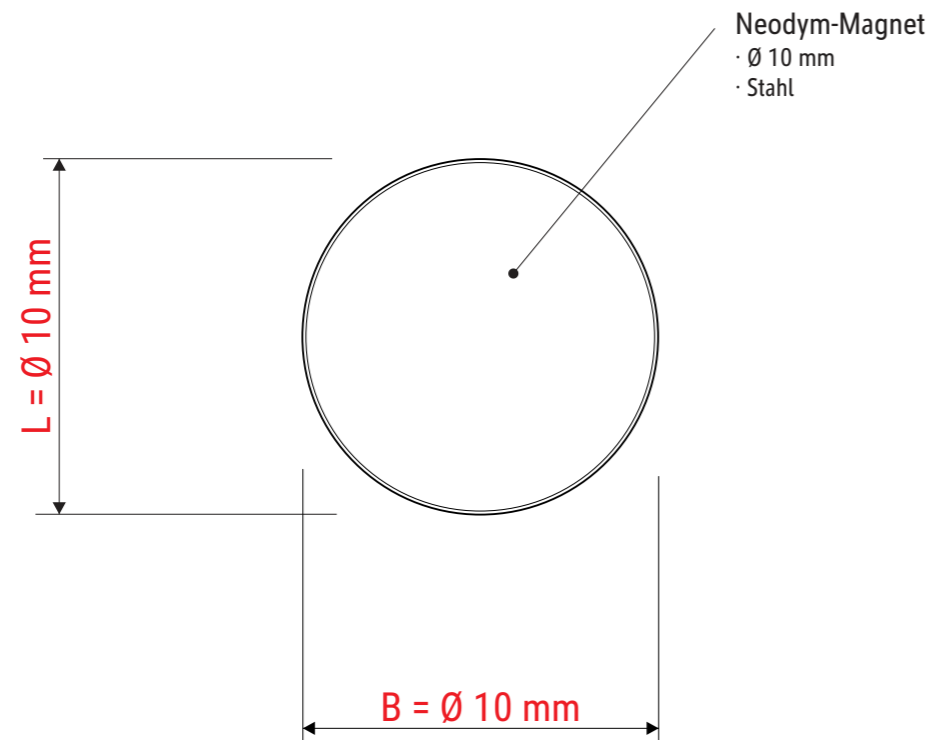

Haftkraft: 2 kg

Abmaße Produkt: **L x B x H**
10 x 10 x 3 mm
Gewicht: 0,0018 kg

Verp. Abmaße : L x B x H (10 Stck. im Karton)
95 x 85 x 23 mm
Gewicht kompl.: 0,050 kg