

Technisches Datenblatt / Technical Datasheet

Art.-No. 16115

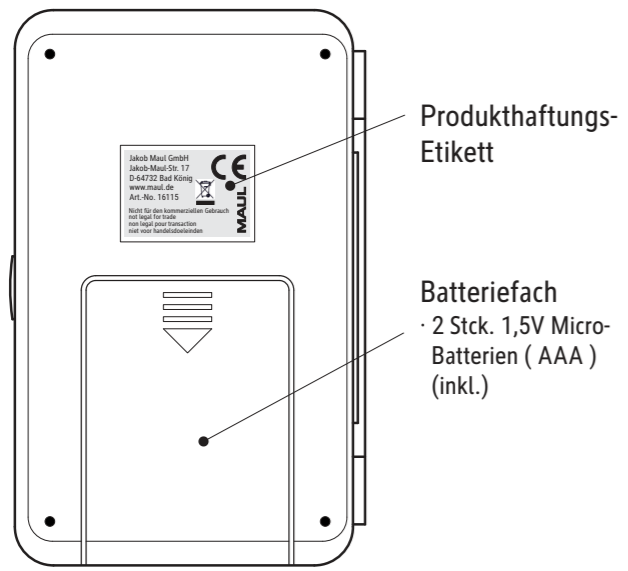

Abmaße Produkt: **L x B x H**
115 x 73 x 18 mm
Gewicht kompl.: 0,323 kg

Verp. Abmaße : L x B x H
182 x 100 x 35 mm
Gewicht kompl.: 0,400 kg

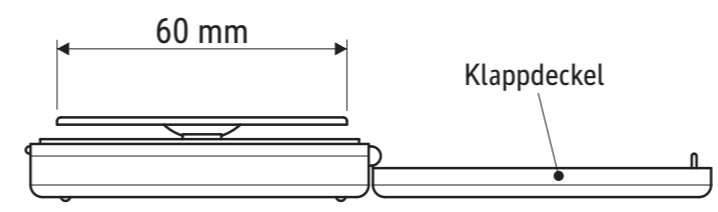
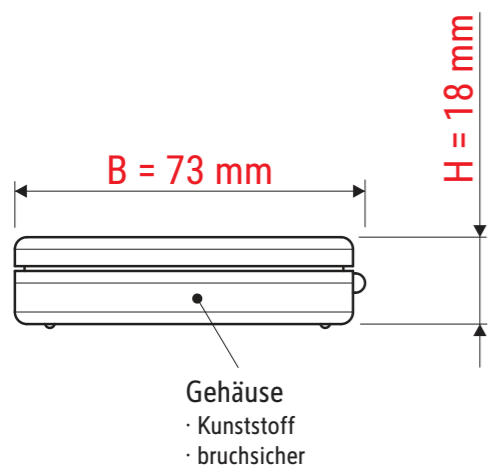

- Tragkraft 500 g
- Teilung 0 - 500 g d = 0,1 g
- Mindestlast 0,7 g
- Benutzerkalibrierung möglich
- Abschaltautomatik
- automatische Nullstellung



Kalibriergewicht
· 200 g (inkl.)

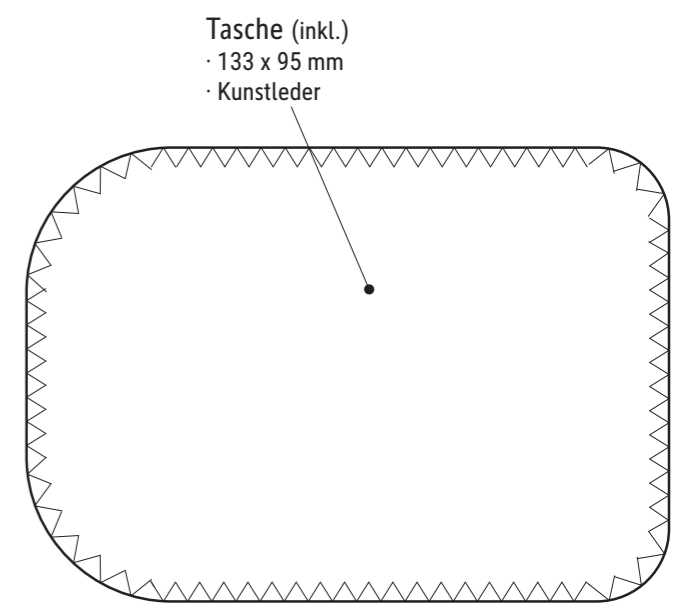
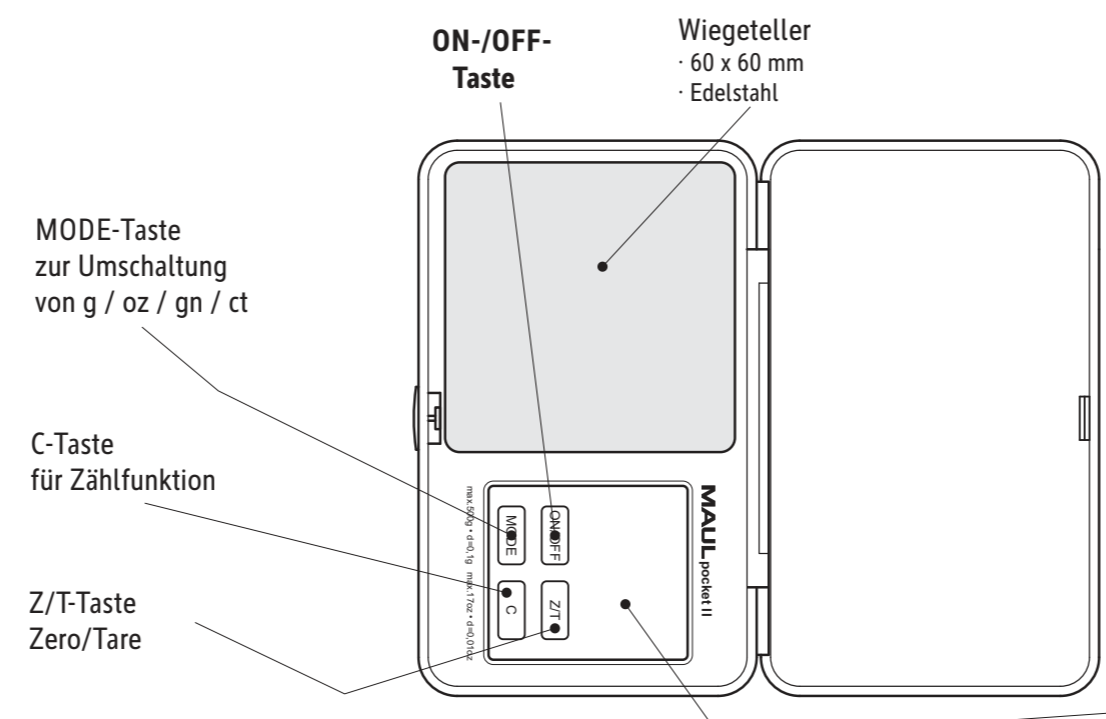
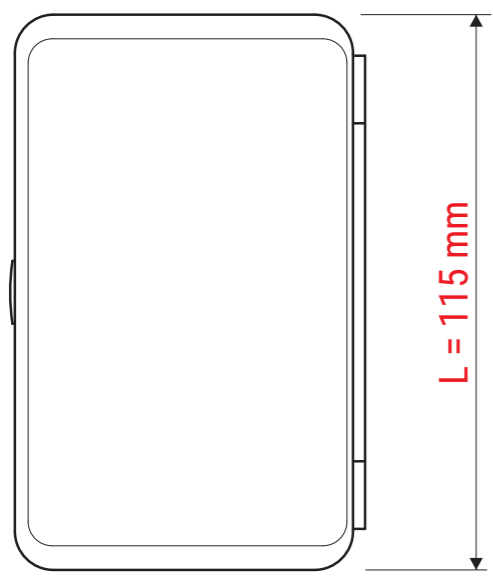

LCD-Anzeige
· 41 x 36 mm
· 4-Tasten Touchfeld-Bedienung