

Technisches Datenblatt / Technical Datasheet

Art.-No. 82021

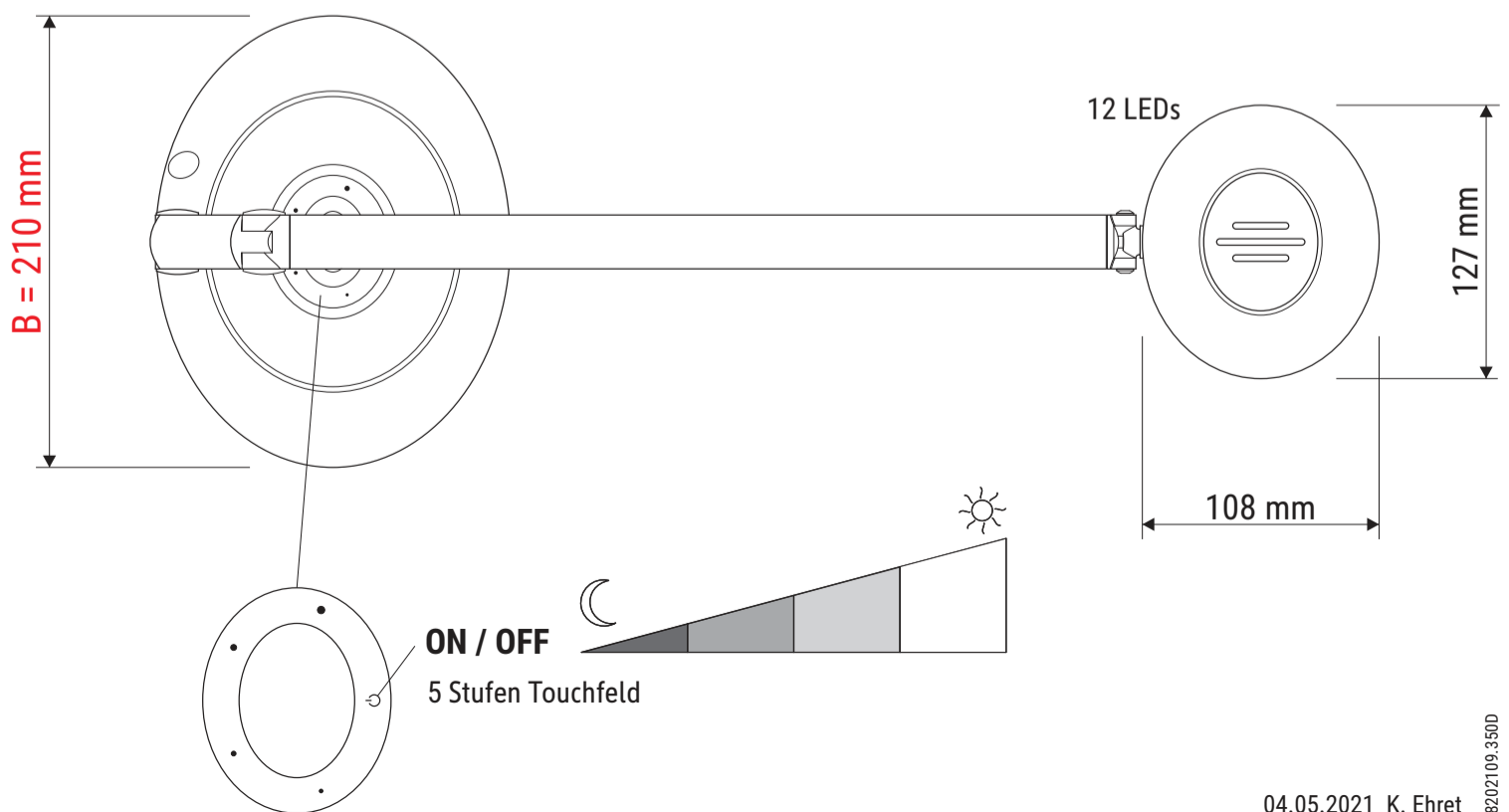
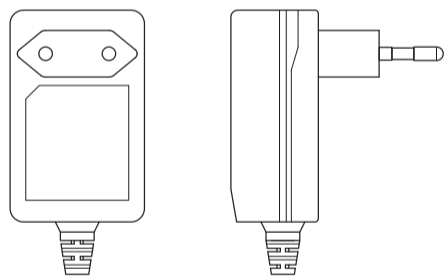
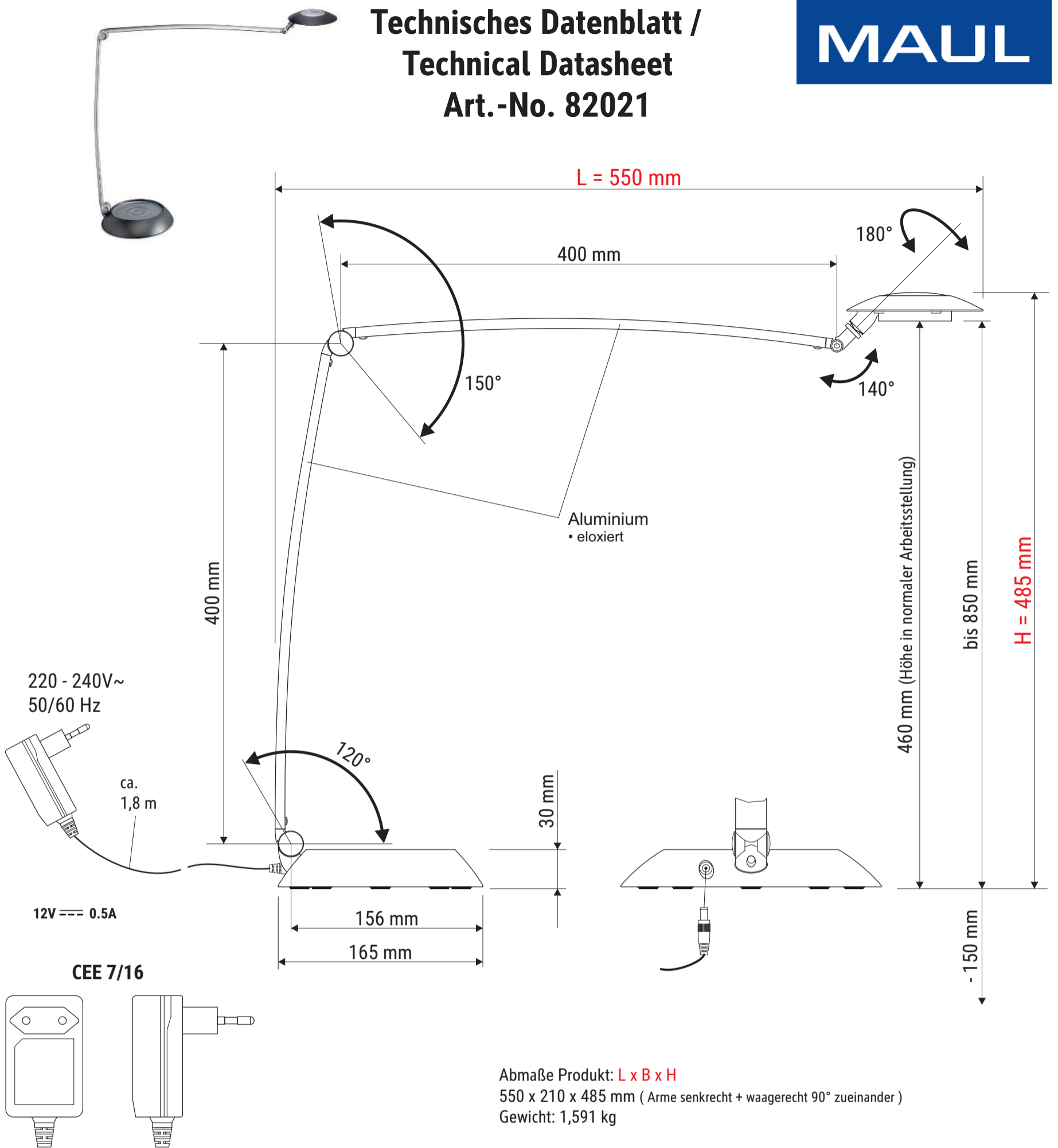

Verp. Abmaße : $L \times B \times H$
 $470 \times 230 \times 190 \text{ mm}$
 Gewicht kompl.: $2,230 \text{ kg}$