

Technisches Datenblatt / Technical Datasheet

Art.-No. 64314

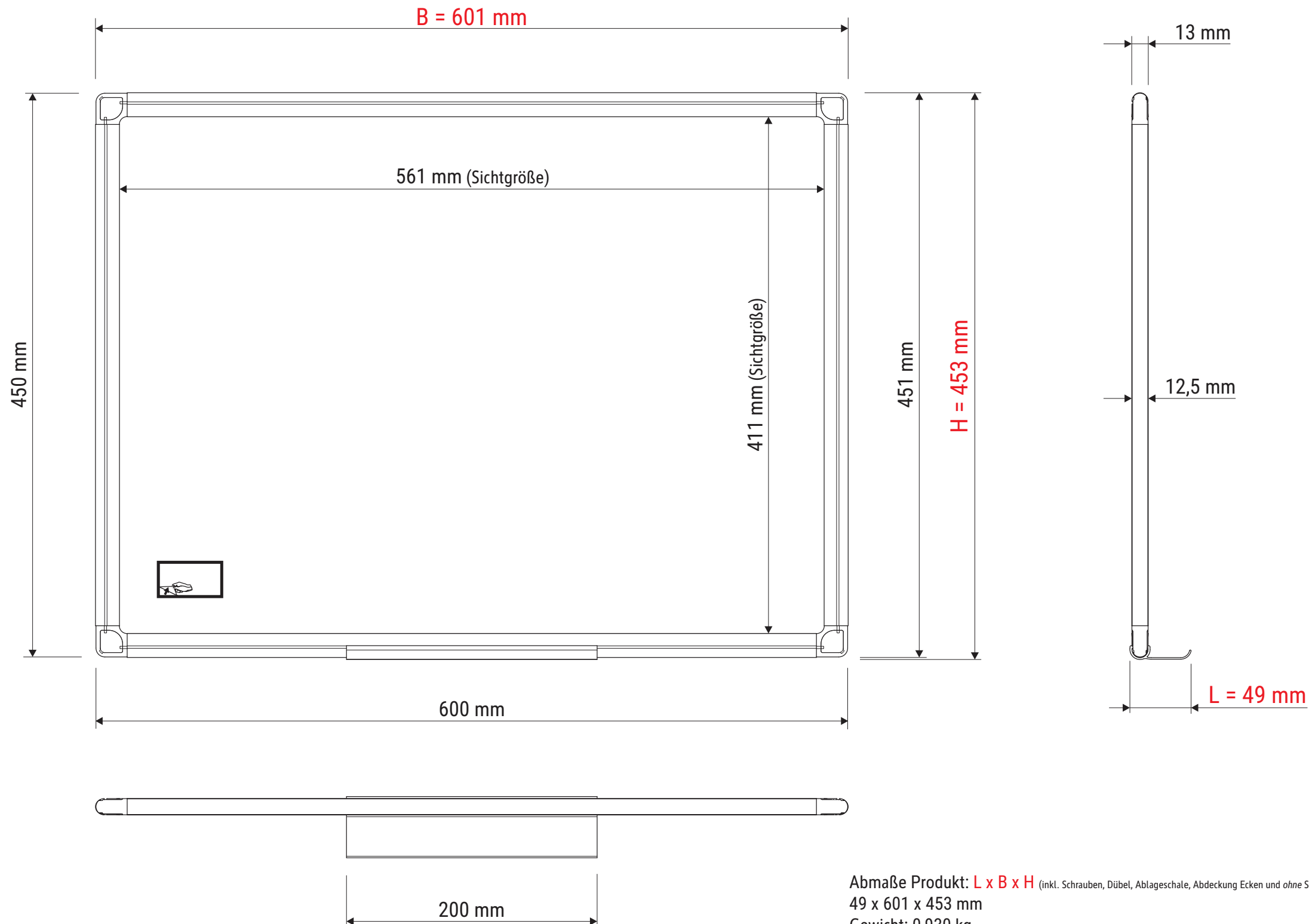

Vorderseite



Zubehör inkl.:

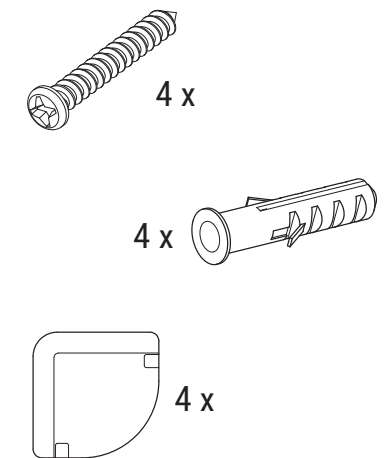

Montagematerial:
(als Ersatzteil lieferbar:
Abpackbeutel Art.-Nr.: 6430809.020)



1 x
(als Ersatzteil lieferbar:
Art.-Nr.: 6431409.050)

Verp. Abmaße : L x B x H
665 x 525 x 35 mm
Gewicht kompl.: 1,388 kg

Abmaße Produkt: **L x B x H** (inkl. Schrauben, Dübel, Ablageschale, Abdeckung Ecken und ohne Schutzfolie)
49 x 601 x 453 mm
Gewicht: 0,930 kg

Technisches Datenblatt / Technical Datasheet

Art.-No. 64314

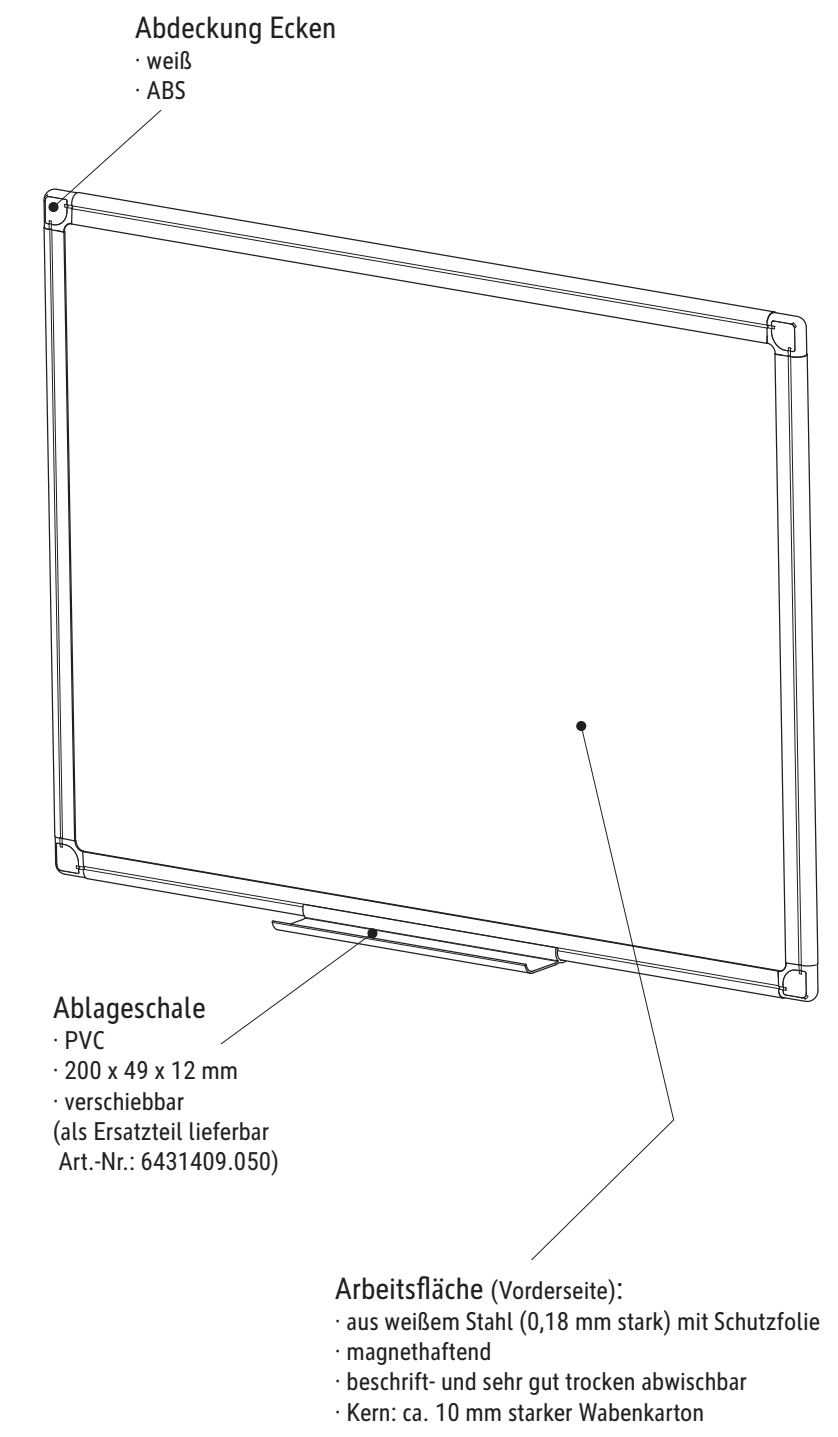
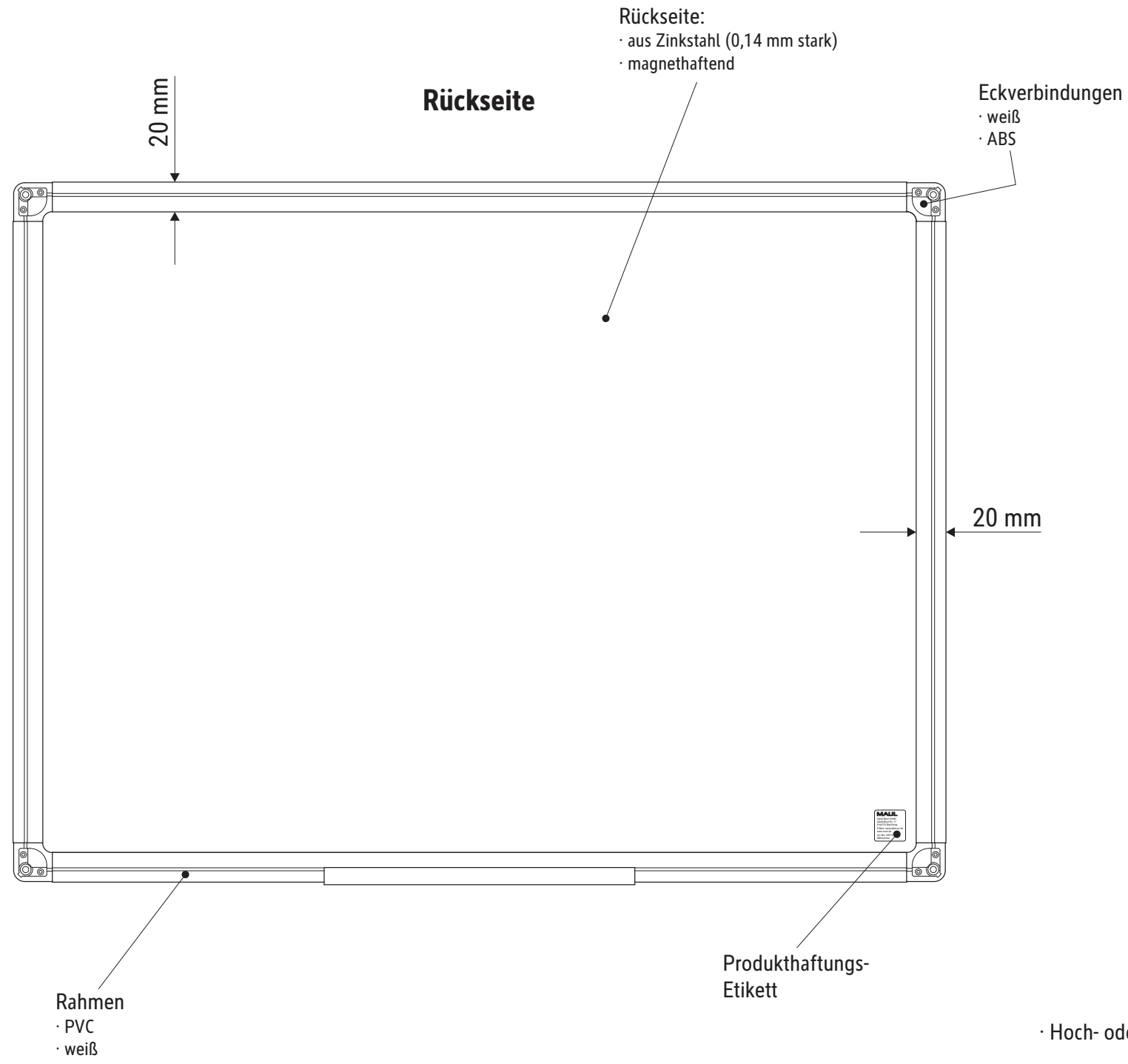

· Hoch- oder Querformat